

USER'S MANUAL & INSTALLATION DIRECTIONS

 **MITSUBISHI**
HEAVY INDUSTRIES, LTD.
AIR-CONDITIONER

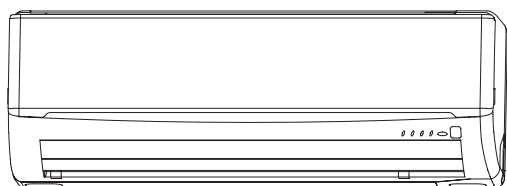

SRK10YL-S
SRK13YL-S
SRK18YL-S

USER'S MANUAL

BUKU PEDOMAN

BUKU PANDUAN PENGGUNA

TÀI LIỆU HƯỚNG DẪN SỬ DỤNG

INSTALLATION DIRECTIONS

PETUNJUK PEMASANGAN

ARAHAN-ARAHAN PEMASANGAN

HƯỚNG DẪN LẮP ĐẶT

Thank you for purchasing a MITSUBISHI HEAVY INDUSTRIES, LTD. Air Conditioner. To get the best long-lasting performance, read and follow this User's Manual carefully before using your air-conditioner.

After reading, please store the Manual in a safe place and refer to it for operational questions or in the event of any irregularities.

This air-conditioner is intended for domestic use.

Terima kasih Anda telah membeli MITSUBISHI HEAVY INDUSTRIES, LTD. Air Conditioner.

Untuk mendapatkan kinerja unit yang terbaik dan tahan lama, silakan Anda membaca dan mengikuti Buku Pedoman Pengguna ini secara seksama sebelum menggunakan air-conditioner ini.

Selesai membaca, simpan kembali Buku Pedoman ini di tempat yang aman dan jadikan buku ini sebagai bahan acuan jika ada yang belum jelas mengenai pengoperasian unit atau jika ada kelainan pada unit.

Air-conditioner ini hanya diperuntukkan di dalam ruangan.

Terima kasih kerana alat penghawa dingin hasil keluaran daripada Industri Berat Mitsubishi, Ltd (MITSUBISHI HEAVY INDUSTRIES, LTD).

Bagi mencapai prestasi penghawa dingin yang terbaik dan penggunaan yang berpanjangan, sila baca dan fahami buku panduan pengguna ini dengan sepenuhnya sebelum menggunakan alat penghawa dingin ini.

Selepas membaca buku panduan ini, sila letakkan buku panduan ini di tempat yang selamat. Sila rujuk kepada buku panduan ini jika anda mempunyai apa-apa soalan tentang pengendalian alat ini ataupun semasa keadaan yang luar biasa.

Alat penghawa dingin ini adalah untuk penggunaan di dalam negara sahaja.

Cám ơn quý khách đã mua Máy Điều hòa Nhiệt độ của công ty MITSUBISHI HEAVY INDUSTRIES, LTD. Để có được hiệu năng lâu dài và tốt nhất, hãy đọc kỹ và tuân theo Tài liệu Hướng dẫn Sử dụng này trước khi sử dụng máy điều hòa nhiệt độ.

Sau khi đọc, hãy lưu trữ Tài liệu hướng dẫn vào một nơi an toàn và tham khảo nếu gặp phải các vấn đề khi vận hành thiết bị.

Máy điều hòa nhiệt độ được sản xuất để sử dụng trong gia đình.

RMA012A031A



USER'S MANUAL

contents

Safety precautions	2
Choice of operations and features	4
Name of each part and its function	5
Operation and indication section for remote control	7
AUTO mode operation procedure	8
Temperature adjustment during AUTO	8
About FAN SPEED	8
COOL/DRY/FAN mode operation procedure	9
Air-conditioner operating conditions	9
Air flow direction adjustment procedure	10
3D AUTO operation procedure	10
SLEEP operation procedure	11
OFF-TIMER operation procedure	11
ON-TIMER operation procedure	12
SLEEP operation + ON-TIMER operation procedure	12
PROGRAM TIMER operation procedure	13
Present time setting procedure	13
HIGH POWER/ECONOMY operation procedure	14
Concerning CLEAN operation	15
Emergency run operation	15
Power blackout auto restart function	15
Installation location setting	16
Remote control handling procedure	17
When the operation fails with the remote control	17
Operating hints	18
Maintenance	18
Has the unit been installed correctly?	20
Troubleshooting	20
Please remember!	21
When to contact your distributor without delay	22
Self diagnosis function	23







Safety precautions

- Before starting to use the system, please read these “Safety precautions” carefully to ensure proper operation of the system.
- The safety precautions are classified as “⚠ DANGER” and “⚠ CAUTION”. Precautions as shown in the column “⚠ DANGER” indicate that improper handling could lead to drastic result like death, serious injury, etc. Even precautions as shown in the column “⚠ CAUTION” might pose a serious problem, depending on the circumstances. Please observe these precautions with great care, since they are essential to your safety.
- Symbols which appear frequently in the text have the following meaning:













	Strictly prohibited		Observe instructions with great care		Provide proper earthing
---	----------------------------	---	---	---	--------------------------------

- When you have read this instruction manual, please keep it without missing. If someone else takes over as operator, make certain that the manual is also passed on to the new operator.

■ INSTALLATION PRECAUTIONS

⚠ DANGER	⚠ CAUTION	
<p>The system is for domestic, residential etc. use.</p> <p> If used in severer environments, such as an engineering workplace, the equipment may function poorly.</p>	<p>Do not install it where flammable gas may leak.</p> <p> Gas leaks may cause fire.</p>	<p>Depending on the place of installation, an earth leakage breaker may be necessary.</p> <p> If you do not install an earth leakage breaker, you may get an electric shock.</p>
<p>The system must be installed by your dealer or a qualified professional.</p> <p> It is not advisable to install the system by yourself, as faulty handling may cause leakage of water, electric shock or fire.</p>	<p>Make sure to install the drain hose properly so that all the water is drained out.</p> <p> Improper installation may lead to water drop in the room resulting in wet furniture.</p>	<p>Make sure that the system has been properly earthed.</p> <p> Earth cables should never be connected to a gas pipe, water pipe, lightning conductor or telephone earth cable. Incorrect installation of the earth cable may produce an electric shock.</p>

■ OPERATION PRECAUTIONS

⚠ DANGER	⚠ CAUTION	
<p>Do not expose yourself to the cooling air for a long period.</p> <p> This could affect your physical condition and cause health problems.</p>	<p>Only use approved fuses.</p> <p> Use of steel or copper wire instead of an approved fuse is strictly prohibited, as it may cause a breakdown or fire.</p>	<p>Do not handle the switches with wet hands.</p> <p> This may cause an electric shock.</p>
<p>Do not insert anything into the air inlet.</p> <p> This may cause injury, as the internal fan rotates at high speed.</p>	<p>Do not swing from the indoor unit.</p> <p> If the indoor unit falls down, you may get injured.</p>	<p>Do not place a flammable insecticide or paint spray near the blower, nor spray it directly on the system.</p> <p> This may result in a fire.</p>
<p>The appliance is not intended for use by persons (including children) with reduced physical, sensory or mental capabilities, or lack of experience and knowledge, unless they have been given supervision or instruction concerning use of the appliance by a person responsible for their safety.</p> <p> Children should be supervised to ensure that they do not play with the appliance.</p>	<p>You should not expose any combustion appliance directly to the air stream of the air-conditioner.</p> <p> The appliance may then work inadequately.</p>	<p>Do not wash the air-conditioner with water.</p> <p> This could cause an electric shock.</p>
<p>Store the remote control out of reach of infants.</p> <p> Failure to observe this may result in the batteries being swallowed or other accidents.</p>	<p>The system should only be used for its original purpose and not for anything else like, for instance, preservation of food, plants or animals, precision devices or works of art.</p> <p> The system is only intended for use in ordinary domestic rooms. Any other use of the system may damage the quality of food, etc.</p>	<p>Do not place anything containing water, like vases, on top of the unit.</p> <p> Water entering the unit could damage the insulation and therefore cause an electric shock.</p>

■ Safety precautions

⚠ CAUTION

Do not install the system where the air-flow direction is aimed directly at plants or animals.



This will damage their health.

Do not sit on the outdoor unit nor put anything on it.



If the unit falls down or things drop off it, people could get hurt.

After a long period of use, check the unit's support structure from time to time.



If you do not repair any damage right away, the unit may fall down and cause personal injury.

Do not touch the aluminum fins on the air heat exchanger.



It may result in injury.

Do not place household electrical appliances or household items under neath the indoor or outdoor units.



Condensation falling from the unit may stain objects and cause accidents or electrical shock.

Do not operate the system without the air filter.



It can cause malfunction of the system due to clogging of the heat exchanger.

Do not shut off the power supply immediately after stopping the operation.



Wait at least 5 minutes, otherwise there is a risk of water leakage or breakdown.

Do not control the system with main power switch.



It can cause fire or water leakage. In addition, the fan can start unexpectedly, which can cause personal injury.

If you operate the system together with a combustion appliance, you must regularly ventilate the indoor air.



Insufficient ventilation may cause accidents due to oxygen deficiency.

Stand firmly on a stepladder or other stable object when removing the inlet panel and filters.



Failure to observe this may result in injury through insecure objects toppling over.

When you clean the system, stop the unit and turn off the power supply.



Never open the panel while the internal fan is rotating.

Do not place objects near the outdoor unit or allow leaves to gather around the unit.



If there are objects or leaves around the outdoor unit, small animals may enter unit and contact electrical parts and may cause a break-down, smoke or fire.

Contact your dealer to clean inside the indoor unit, do not attempt to do by yourself.



The use of a non-approved detergent or improper washing method may damage the unit's plastic components and cause leaks. Damage, smoke, or fire may also happen if the detergent comes in contact with electrical parts or the unit's motor.

Stop the unit and turn off the power if you hear thunder or there is a danger of lightning.



It may damage the unit.

■ PRECAUTIONS FOR RELOCATION OR REPAIRS

⚠ DANGER

Do not perform any repairs or modifications by yourself. Consult the dealer if the unit requires repair.



If you repair or modify the unit, it can cause water leaks, electric shocks or fire.

Consult your dealer for repairs.



Wrong repairs could cause an electric shock, fire, etc.

In case the air-conditioner is relocated elsewhere, contact your dealer or a professional fitter.



Faulty installation may cause water leakage, electric shock, fire, etc.

If you notice anything abnormal (smell of burning, etc.), stop the system, turn off the power supply and consult your dealer.



Continued use of the system in abnormal circumstances may result in malfunctioning, electric shock, fire, etc.

If the air-conditioner fails to cool or warm the room, it may have a refrigerant leakage. Contact your dealer. If refrigerant needs to be added, check with your dealer for proper instructions.



If the refrigerant comes in contact with the bare skin, it may cause cold injury. If the refrigerant gas is inhaled excessively, it may cause deterioration of nerve function like dizziness and headache, or deterioration of heart function like irregular heartbeat and heart palpitation temporarily. If refrigerant unexpectedly leaks from the unit onto a fan heater, stove, hotplate or other heat source, harmful gases could be generated.

Choice of operations and features

Choice of operations

COOL

👉 Page 9

Cooling by extracting heat from the room.

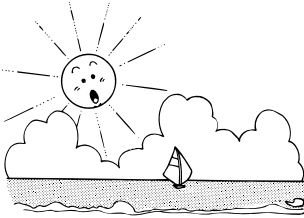

DRY

👉 Page 9

Drying by extracting damp from the room.



Functioning of microcomputer depends on setting and room temperatures. It dehumidifies while keeping room temperature almost constant.

FAN

👉 Page 9

Fanning by circulating room air.

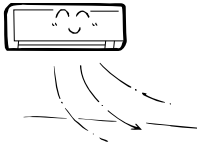

AUTO

👉 Page 8

Automatic selection of operating mode.

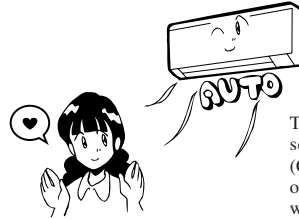

The Auto mode automatically selects the operation mode (COOL or DRY), depending on the room temperature when switched on.

Features

Amenity facility

👉 Page 13

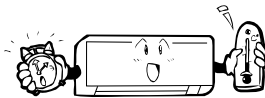

When using the timer to switch on, the system should become operational shortly before the set time, depending on the room temperature so that the desired temperature should be reached at the set time.

TIMER procedure

👉 Page 11, 12



There are three timers, for SLEEP, ON and OFF. They can be set as desired.

HIGH POWER mode

👉 Page 14

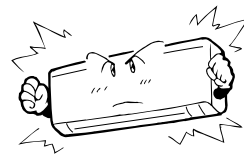

Turning up the power operates the air-conditioner in the power cooling mode.

Adjustment of airflow

👉 Page 10

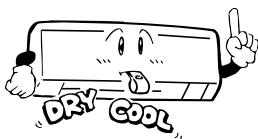

- **SWING FLAP**
Flap moves up and down continuously.
- **SWING LOUVER**
Louver moves left and right continuously.
- **MEMORY FLAP (FLAP OR LOUVER STOPPED)**
Once the flap or louver position has been set, the unit will memorise it and continue in the same position the next time.

ECONOMY mode

👉 Page 14

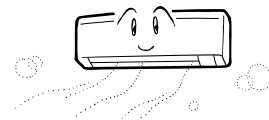

This is an economic level of operation.

Name of each part and its function

INDOOR UNIT

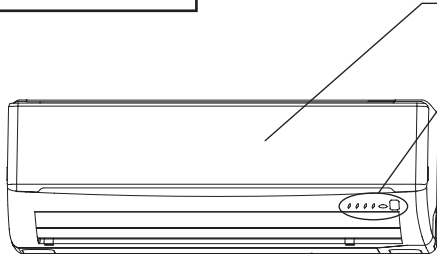

Air inlet panel

Draws in the indoor air.

Unit indication section and remote control signal receiver

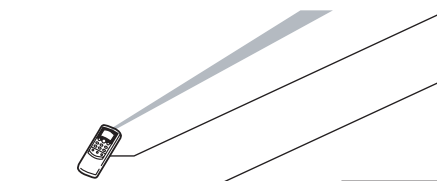

Wireless remote control

Air filter

Removes dust or dirt from the inlet air.

Page 18

Air-cleaning filter

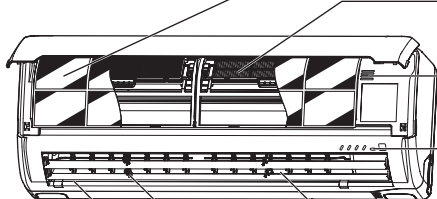

Room temperature detector

Unit operation switch

Air outlet

Air blows out of here.

Left/right air flow adjustment louver

Page 10

Up/down air flow direction adjustment flap

Page 10

Drain hose

Drains water from the dehumidified air.

Refrigerant piping connection electric flex

OUTDOOR UNIT

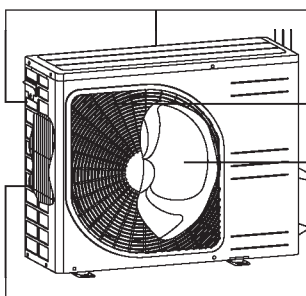

Air inlet

(On side & rear surface)

Air outlet

Outdoor unit fan

Heat exchanger

Accessories



Wireless remote control



Wireless remote control holder



Battery (R03×2)



Wood screw (Quantity:2)
(for remote control holder mounting)

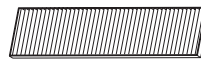

Natural enzyme filter
(Green)



Photocatalytic washable deodorizing filter (Orange)

Unit indication section

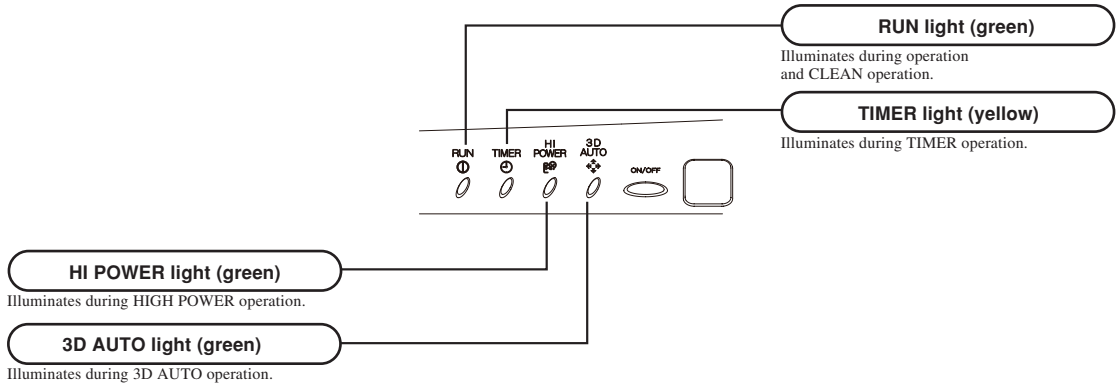

How to open the air inlet panel

Place fingers at the recesses on both sides of the panel and pull up the panel to this side so that it will be opened by about 60 degrees.

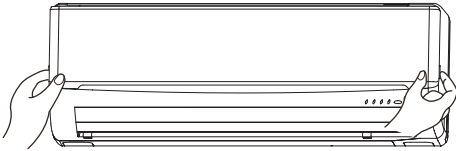

Unit ON/OFF button

In emergencies, this button can be used for turning on/off the unit when remote control is not available.  Page 15

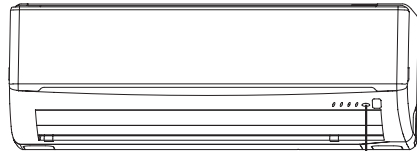

Unit ON/OFF button

How to close the air inlet panel

Push both sides evenly and press further lightly at the center.

Removal, installation of air inlet panel

When removing the air inlet panel for internal cleaning or others, open the panel by 80 degrees and then pull it to this side.

Secure either the upper or lower edge of the air inlet panel by lightly pushing it in, and then close the panel.

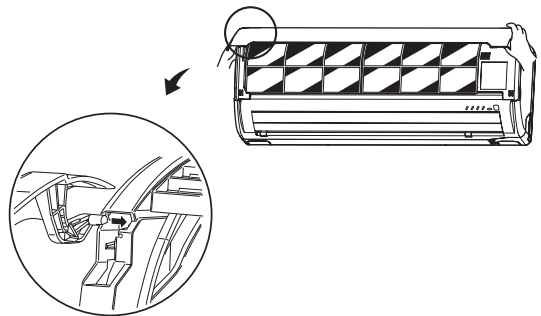
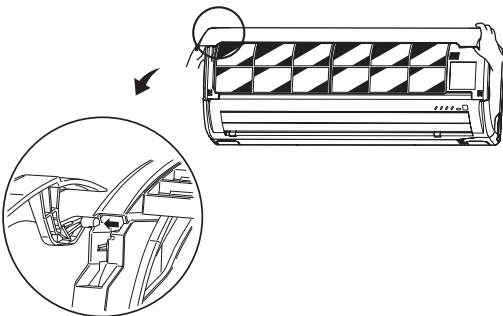

Operation and indication section for remote control

Operation section

FAN SPEED button

Each time the button is pushed, the ■ indicator is switched over in turn.

HI POWER/ECONO button

This button changes the HIGH POWER/ECONOMY mode.

☞ Page 14

TEMPERATURE button

This button sets the room temperature. (This button changes the present time and TIMER time.)

ON TIMER button

This button selects ON TIMER operation.

☞ Page 12

SLEEP button

This button changes to SLEEP operation.

☞ Page 11

CLEAN switch

This switch changes the CLEAN mode.

☞ Page 15

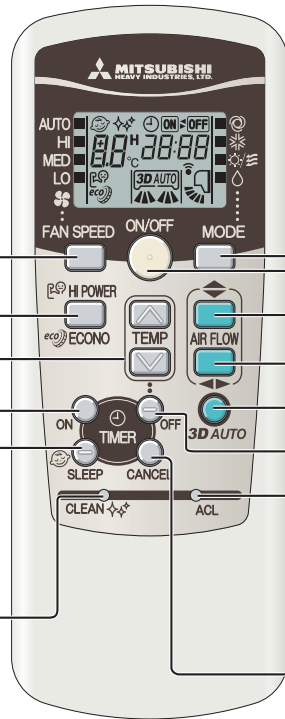

OPERATION MODE select button

Each time the button pushed, the ■ indicator is switched over in turn.

ON/OFF (luminous) button

Press for starting operation, press again for stopping.

AIR FLOW (UP/DOWN) button

This button changes the air flow (up/down) mode.

☞ Page 10

AIR FLOW (LEFT/RIGHT) button

This button changes the air flow (left/right) mode.

☞ Page 10

3D AUTO button

This button sets 3D AUTO operation.

☞ Page 10

OFF TIMER button

This button selects OFF TIMER operation.

☞ Page 11

RESET switch

Switch for resetting microcomputer and setting time.

☞ Page 13, 17

CANCEL button

This button cancels the ON timer, OFF timer, and SLEEP operation.

• The above illustration shows all controls, but in practice only the relevant parts are shown.

Indication section

CLEAN indicator

Indicates during CLEAN operation.

SLEEP indicator

Indicates during SLEEP operation.

TEMPERATURE indicator

Indicates set temperature. (Does not indicate temperature when operation mode is on AUTO)

FAN SPEED indicator

Indicates set air flow rate with ■ lamp.

HI POWER/ECONO MODE indicator

Indicates during HIGH POWER/ECONOMY mode operation.

ON/OFF TIMER indicator

Indicates during ON/OFF TIMER operation.

OPERATION MODE indicator

Indicates selected operation with ■ lamp. [☉ (Auto) •* (Cool) •☼ (Fan) •△ (Dry)]

TIME indicator

Indicates present time or timer setting time.

AIR FLOW indicator

Shows selected flap and louver mode.

3D AUTO indicator

Indicates during 3D AUTO operation.



Transmission procedure

When each button on the remote control is pressed with the remote control pointing towards the air-conditioner unit a signal is transmitted. When the air-conditioner receives the signal correctly, it will beep.

AUTO mode operation procedure

- Automatically selects the operation mode (COOL, DRY) depending on the room temperature when switched on.

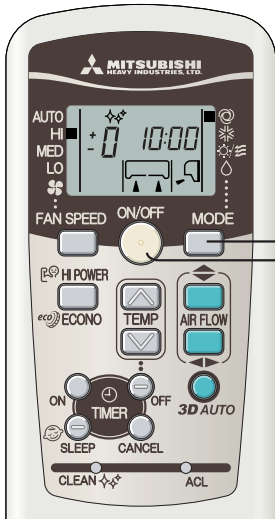

When the unit is not in AUTO mode:

1

Press MODE button.

Move the [■] mark to the (Auto) position.

Aim the remote control at the air-conditioner.

2

Press the ON/OFF button.

To stop:

Press the ON/OFF button.

NOTE

- Air is not blown out during the operation.

➔ Page 21

AUTO mode can be operated by simply pressing the ON/OFF button.



- If you don't want the AUTO mode program, change to COOL, DRY or FAN instead of AUTO.

➔ Page 9

Air flow direction adjustment procedure. ➔ Page 10

Temperature adjustment during AUTO

- Air temperature adjustment is possible even during automatic operation. There are 6 levels of adjustment possible with the (▲) button or the (▼) button.

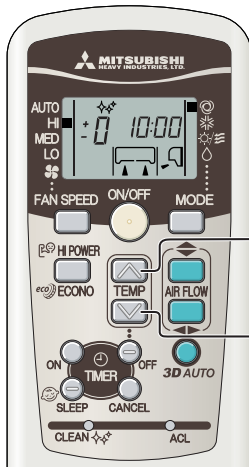

When a change in temperature is desired.

1

Press the (▲) or (▼) button.

When it is a little cold

Press the (▲) button.

- Each time the (▲) button is pressed, the switch over occurs in the following order -6 → -5 → -1 → ±0 → +1 +6.
When +6 is indicated, even if the (▲) button is pressed, the indicator does not change.

When it is a little hot

Press the (▼) button.

- Each time the (▼) button is pressed, the switch over occurs in the following order +6 → +5 → +1 → ±0 → -1 -6.
When -6 is indicated, even if the (▼) button is pressed, the indicator does not change.

About FAN SPEED

- You can choose the capacity of your air-conditioner when cooling or fan.

Operation capacity by your choice	FAN SPEED
Set automatically by microcomputer	AUTO
Powerful operation with high capacity	HI
Standard operation	MED
Energy-saving operation	LO

Press the FAN SPEED button.

Move the [■] mark to the desirable fan speed position.

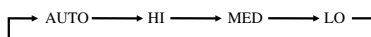

COOL/DRY/FAN mode operation procedure

Aim the remote control at the air-conditioner.

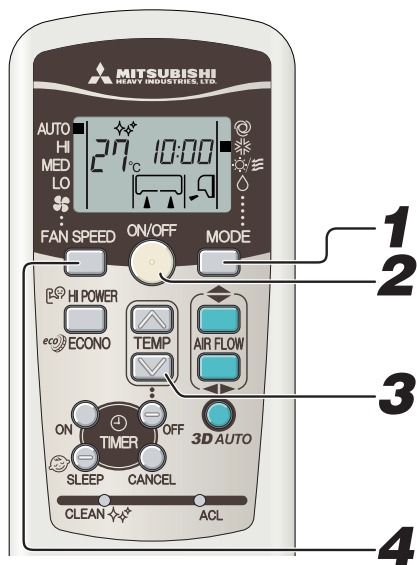

1

Press the MODE select button.

Move the [■] mark to the desirable operation position.

* (Cool), ☀/☾ (Fan), △ (Dry)

2

Press the ON/OFF button.

3

Press the TEMP button.

Press ▲ or ▼ button for the desired temperature.

Standard

COOL	26°C-28°C	DRY	21°C-24°C	FAN	—
------	-----------	-----	-----------	-----	---

4

Press the FAN SPEED button

Set the fan speed as desired.

Air flow direction adjustment procedure. Page 10

NOTE

- Air is not blown out during the operation.

Page 21

To stop:

Press the ON/OFF button.

Program changing procedure

Set the new program.

- The operation program can also be set or changed when the air-conditioner is not in operation.

Air-conditioner operating conditions

- Use within the following operational range. Operating outside of this range may result in the protection devices being activated, preventing the unit from working.

	Cooling operation
Outside temperature	Approximately 21 to 43 °C
Inside temperature	Approximately 21 to 32 °C
Inside humidity	Below approximately 80% The long-term use of the unit with a humidity level exceeding 80% may result in condensation forming on the surface of the indoor unit, leading to water drips.

Air flow direction adjustment procedure

Adjusting air flow direction

- Up/down direction can be adjusted with the AIRFLOW $\blacktriangleup/\blacktriangledown$ (UP/DOWN) button on the remote control. Each time when you press this button the mode changes as follows:
Change to AIRFLOW (UP/DOWN) mode.

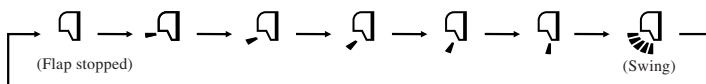

- Left/right direction can be adjusted with the AIRFLOW $\blacktriangleleft/\blacktriangleright$ (LEFT/RIGHT) button on the remote control. Each time when you press this button the mode changes as follows:
Change to AIRFLOW (LEFT/RIGHT) mode.

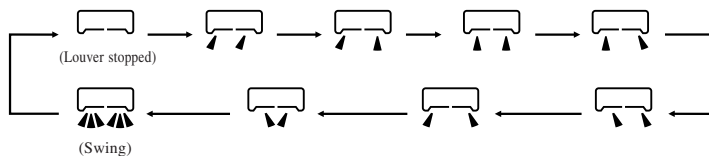

MEMORY FLAP (FLAP OR LOUVER STOPPED)

When you press the AIRFLOW (UP/DOWN or LEFT/RIGHT) button once while the flap or louver is operating, it stops swinging at an angle. Since this angle is memorized in the microcomputer, the flap or louver will automatically be set at this angle when the next operation is started.

⚠ DANGER

- Avoid constant airflow to the body for hours on end.

⚠ CAUTION

- When in COOL or DRY operation, do not operate for hours on end with the air flow blowing straight down. Otherwise, condensation may appear on the outlet grill and drip down.
- Do not try to adjust the flaps and louvers by hand, as the control angle may change or the flap or louver may not close properly.

- Recommended angle of the flap when stopping

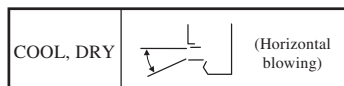

3D AUTO operation procedure

- Fan speed and air flow direction are automatically controlled, allowing the entire room to be efficiently conditioned.

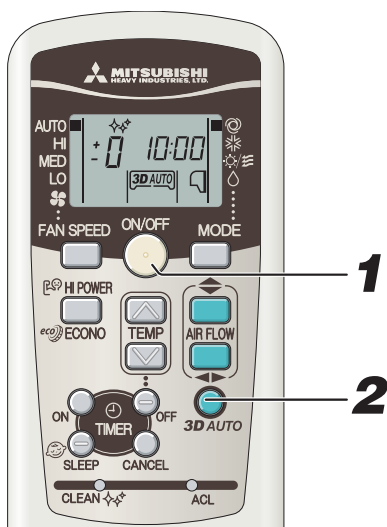

1

Press the ON/OFF button.

2

Press the 3D AUTO button.

Each time the 3D AUTO button is pressed, the indicator is switched in the order of:

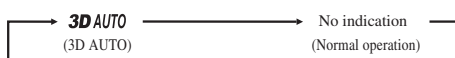

Releasing procedure

Press the 3D AUTO button to turn off the 3D AUTO indicator.

NOTE

- 3D AUTO operation is cancelled when you switch the operation program.
- The 3D AUTO light illuminates during 3D AUTO operation.

SLEEP operation procedure

- The unit stops automatically at the end of the set period of time. The room temperature is automatically controlled when the set time lapses, so that the room does not become too cold during cooling.

Page 13



1

Press the SLEEP button.

- If this is pressed while the unit is off**
SLEEP operation starts with the previous operation settings, and the air conditioning is turned off after the time that has been set passes.
- If this is pressed while the unit is running**
Each time the button is pressed, the indication changes as follows:

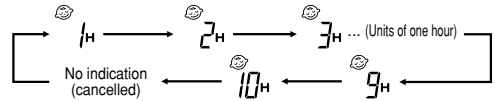

Example: You wish it to stop after 7 hours.

Set to 7H

The timer light (yellow) is on.

- The unit stops at the end of the set period of time.

Changing of set time

Set to a new time by using SLEEP button.

Releasing procedure

Press the CANCEL button to turn off the SLEEP indicator.

OFF-TIMER operation procedure

- The unit stops automatically at the end of the set period of time. If it is stopped, perform the operations starting with STEP 1 and if running start with STEP 2.

Example: You wish it to stop 22:30.

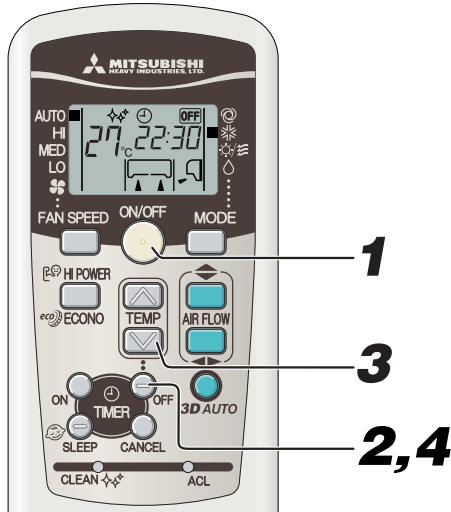

1

Press the ON/OFF button.

2

Press the OFF TIMER button.

OFF TIMER indicator OFF is blinking.

3

Press the “☒ or ☑” button.

Each time the ☒ button is pressed, the indicator is switched in the order of:

0:00 → 0:10 → 0:20 → ... → 1:00 → 1:10 → (Units of ten minutes)

Each time the ☑ button is pressed, the indicator is switched in the order of:

0:00 → 23:50 → 23:40 → ... → 23:00 → 22:50 → (Units of ten minutes)

Set at 22:30.

4

Press the OFF TIMER button.

Press within 60 sec.!

The indication changes from blinking to steady lighting and the setting is complete. The timer light (yellow) is on.

- The unit stops at the end of the set period of time.

Changing of set time

Set a new time by using the OFF TIMER button.

Releasing procedure

Press the CANCEL button to turn off the timer indicator.

ON-TIMER operation procedure

- Operation starts 5 to 60 minutes before the time that is set so that the room temperature reaches the optimum temperature at that time.  Page 13
ON-TIMER operation can be set regardless of whether the air-conditioner is running or not.

Example: In the case you wish to bring the temperature to nearly set temperature in at 8:00.

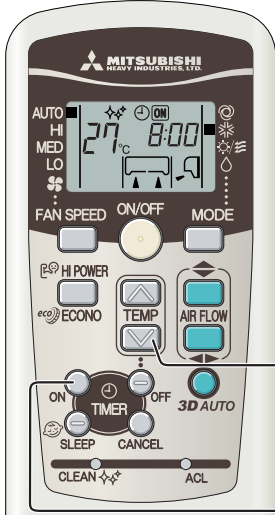

1

Press the ON-TIMER button.

ON TIMER indicator  is blinking.

2

Press the “ or ” button.

Each time the  button is pressed, the indicator is switched in the order of:

→0:00→0:10→0:20→...→1:00→1:10→ (Units of ten minutes)

Each time the  button is pressed, the indicator is switched in the order of:

→0:00→23:50→23:40→...→23:00→22:50→ (Units of ten minutes)

Set at 8:00.

3

Press the ON TIMER button.

Press within
60 sec.!

The indication changes from blinking to steady lighting and the setting is complete. The timer light (yellow) is on.



- Operation starts 5 to 60 minutes before the set time.
- The TIMER light goes out at the set time.

Changing of set time

Set a new time by using the ON-TIMER button.

Releasing procedure

Press the CANCEL button to turn off the timer indicator.

SLEEP operation + ON-TIMER operation procedure

- Combined timer operation of SLEEP operation and ON TIMER. 1-time event setting.

Example: When it is desired to stop after 3 hours and then start operation at 8:00, near the set temperature.



SLEEP operation setting

Set by the procedures on page 11.

Set to  3H

ON TIMER operation setting

Set by the above mentioned ON TIMER operation procedure.

Set to  8:00

The setting of the lighting of the timer light (yellow) of this unit is complete.



- After the SLEEP operation set time has elapsed, the operation stops, and it starts from 5 to 60 minutes before the ON TIMER's time.
- The timer light is not lit at the ON TIMER's time.

Changing of set time

Set a new time by using the SLEEP or ON TIMER button.

Releasing procedure

Press the CANCEL button to turn off the timer indicator.

PROGRAM TIMER operation procedure

- The timer operations that consist of the combination of the timer being set at both on and off. Once this has been set and operations started, operations will commence and end at the same time every day as long as the ON/OFF button is not pressed.



Example: When it is desired to stop at 22:30, and then start operation at 8:00, near the set temperature.

OFF TIMER operation setting

Set by the procedures on page 11. Set to  22:30

ON TIMER operation setting

Set by the procedures on page 12. Set to  8:00

The setting of the lighting of the timer light (yellow) of this unit is complete.

The time will be displayed on the remote control unit. The display will change depending on the operational status.



(Stopped)



(Operating)

Changing of set time

Set a new time by using the OFF TIMER or ON TIMER button.

Releasing procedure

Press the CANCEL button to turn off the timer indicator.

About Amenity facilities

Amenity facilities enable to start the operation a little earlier, so that the room should approach optimum temperature at ON time when the operation is started by ON-TIMER.

- Mechanism**
The room temperature is checked 60 minutes before the timer is at ON. Depending on the temperature at that time, the operation starts 5 to 60 minutes before the timer is at ON.
- The Amenity facility only functions for COOL operation mode (including AUTO). It does not work for DRY mode.

► In COOL operation ◀
(Stop) Operation starts

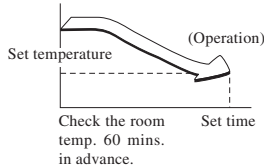

About SLEEP operation

When SLEEP operation is selected, the room temperature is automatically controlled after a while, ensuring that the room is not too cold during cooling or too warm during heating.

- During COOL : the preset temperature is lowered by 1°C at the start of SLEEP operation (when the timer is set). After that, the temperature goes up by 1°C every an hour to become 2°C higher.

Present time setting procedure

- When inserting the batteries, the present time is automatically set to time setting mode.

Example: Set to 10:30.

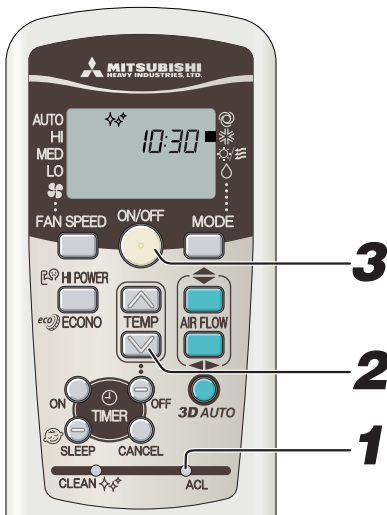

1

Press the ACL switch.

Press with the tip of a ballpoint pen, etc.
The time indicator blinks and can be set to the current time.

2

Press the "▲ or ▼" button.

(Set to 10:30)

3

Press the ON/OFF button.

The indication changes from blinking to steady lighting and the setting is complete.

Press within
60 sec.!

NOTE

- The timer operation is set on the basis of the present time, so please set it correctly.
- The remote control data is reset when the present time is set.

HIGH POWER/ECONOMY operation procedure

If the air-conditioner is not operating, aim the remote control at the air-conditioner.

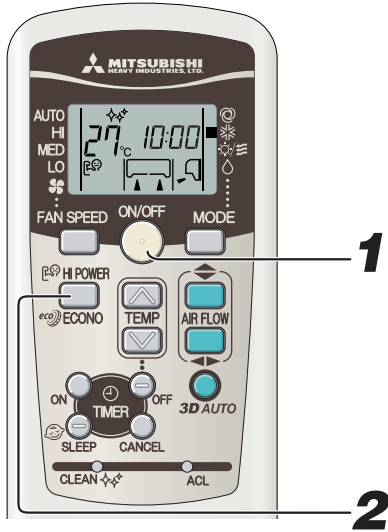

1

Press the ON/OFF button.

2

Press the HI POWER/ECONO button.

- When the operating mode is AUTO or COOL

Each time the HI POWER/ECONO button is pressed, the indicator is switched in the order of:



- When the operating mode is DRY or PROGRAM TIMER

Each time the HI POWER/ECONO button is pressed, the indicator is switched in the order of:

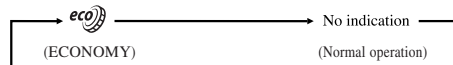

Concerning HIGH POWER operation

Pressing the HI POWER/ECONO button intensifies the operating power and initiates powerful cooling operation for 15 minutes continuously. The remote control indicates but the FAN SPEED indication is erased.

NOTE

- During the HIGH POWER operation, the room temperature is not controlled. When it causes an excessive cooling, press the HI POWER/ECONO button once more to cancel the HIGH POWER operation.
- HIGH POWER operation is not available during the DRY, the program timer operations and 3D AUTO operation.
- During ON timer operation, HIGH POWER operation will start when the ON time is reached.
- When the following operations are conducted HIGH POWER operation will be canceled.
 - When the HI POWER/ECONO button is pressed again.
 - When the operation mode is changed.
 - When it has been 15 min. since HIGH POWER operation has started.
 - When the 3D AUTO button is pressed.

Concerning ECONOMY operation

Pressing the HI POWER/ECONO button initiates a soft operation with the power suppressed in order to avoid an excessive cooling. The unit operates 1.5°C higher than the setting temperature for weak wind capacity during cooling. The remote control indicates but the FAN SPEED indication is erased.

NOTE

- It will go into ECONOMY operation the next time the air-conditioner runs in the following instances.
 - When the air-conditioner is stopped using the ON/OFF button.
 - When the air-conditioner is stopped in SLEEP or OFF TIMER operation.
 - When CLEAN operation ends.
- When the following operations are conducted ECONOMY operation will be canceled.
 - When the HI POWER/ECONO button is pressed again.

Concerning CLEAN operation

- CLEAN operation should be run after AUTO, COOL and DRY operation to remove the moisture from inside the indoor unit and control the growth of mold and bacteria.



1

Press the CLEAN switch with the tip of a ballpoint pen.

Each time the CLEAN switch is pressed, the indicator is switched in the order of:

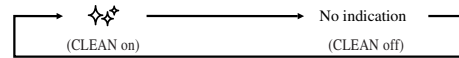

To stop:

Press the ON/OFF button.

NOTE

- CLEAN operation is impossible after Fan, OFF-TIMER and SLEEP have stopped.
- The indoor unit fan runs for about two hours in CLEAN operation.
- The RUN light illuminates during CLEAN operation.

Emergency run operation

- The unit ON/OFF button on the unit operates ON/OFF temporarily when the remote control is not used.

Operation program

- OPERATION MODE : AUTO
- FAN SPEED : AUTO
- AIR FLOW : AUTO

- Operation starts by pressing the unit ON/OFF button; it stops if you press the button again.

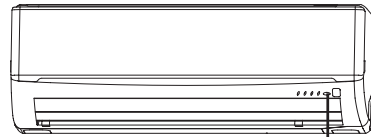

Unit ON/OFF button

Power blackout auto restart function

■ What is power blackout auto restart function?

- Power blackout auto restart function is a function that records the operational status of the air-conditioner immediately prior to it being switched off by a power cut, and then automatically resumes operations at that point after the power has been restored.
- The following settings will be cancelled:
 - ① Timer settings
 - ② HIGH POWER operations

NOTE

- The power blackout auto restart function is set at on when the air-conditioner is shipped from the factory. Consult with your dealer if this function needs to be switched off.
- When power failure occurs, the timer setting is cancelled. Once power is resumed, reset the timer.

Installation location setting

■ Take the air conditioning unit's location into account and adjust the left/right airflow range to maximize air-conditioning.

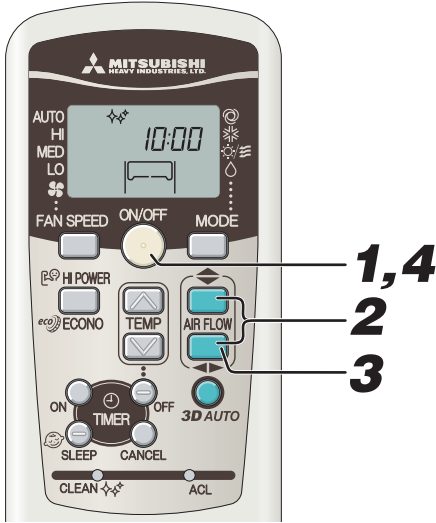

1

If the air conditioning unit is running, press the ON/OFF button to stop.

The installation location setting cannot be made while the unit is running.

2

Press the AIR FLOW \updownarrow (UP/DOWN) button and the AIRFLOW \leftarrow (LEFT/RIGHT) button together for 5 seconds or more.

The installation location display illuminates.

3

Setting the air-conditioning installation location.

Press the AIR FLOW \leftarrow (LEFT/RIGHT) button and adjust to the desired location.

Each time the AIR FLOW \leftarrow (LEFT/RIGHT) button is pressed, the indicator is switched in the order of:



4

Press the ON/OFF button.

Press within 60 sec.!

The air-conditioner's installation location is set.

Press within 60 seconds of setting the installation location (while the installation location setting display illuminates).

Air conditioner installation location and airflow range

The diagram below indicates the airflow ranges corresponding to the air-conditioner's installation location. Consider your room's layout and set the airflow range to maximize conditioning effectiveness.

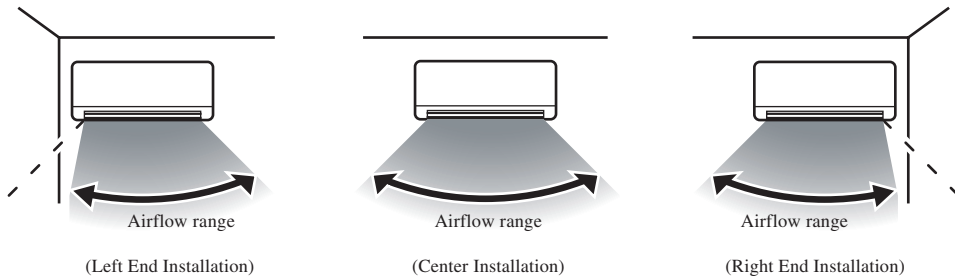

General Information

- \square mark will be displayed on the display panel while the air conditioner is in operation, regardless of the installation location of the unit.
- When installation location of the air conditioner had been set once, installation location will be memorized into the unit even if unplugging the power cord. Please set it with a remote control again in case of changing the installation location of the unit.
- The installation location setting can not be performed while the unit is in operation.

Remote control handling procedure

Replacing the batteries

The following cases signify exhausted batteries. Replace old batteries with new ones.

- Receiving beep is not emitted when a signal is transmitted.
- Indicator fades away.

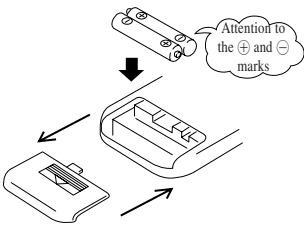
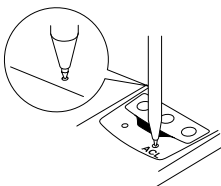
<p>1 Remove back lid and take out old batteries.</p>	<p>3 Close back lid.</p>
<p>2 Insert new batteries. R03(AAA, Micro)x2</p> 	<p>4 Press the reset switch with the tip of a ballpoint pen.</p> <p>The time setting mode is indicated.</p> 

Using the remote control holder

The remote control can be attached to a wall or pillar by using a remote control holder. Before installing the remote control, check that the air-conditioner receives the signals properly.

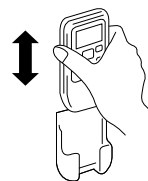

For installing or removing the remote control, move it up or down in the holder.





NOTE

- Don't use old and new batteries together.
- Remove the batteries when the remote control is not used for a long period.
- The life of a battery conforming to JIS or IEC should be 6 to 12 months with normal use. If used longer, or when an unspecified battery is used, liquid may leak from the battery, causing the remote control to malfunction.

When the indicator shows any abnormal condition, Press the reset switch with the tip of a ballpoint pen.

- On the battery is printed its expected life. This may be shorter than that of the air-conditioner, depending on the date of manufacture.
- However, the battery may still be in working order after expiry of its nominal life.

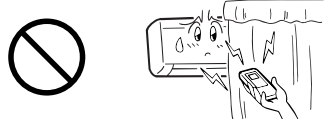
Warning note for remote control handling

<ul style="list-style-type: none"> • Don't go near high temperature places, such as an electric carpet or stove. 	<ul style="list-style-type: none"> • Don't leave the remote control exposed to direct sunlight or other strong lighting. 	<ul style="list-style-type: none"> • Don't drop the remote control. Handle with care. 
<ul style="list-style-type: none"> • Don't put any obstructing obstacles between the remote control and the unit. 	<ul style="list-style-type: none"> • Don't spill water etc on the remote control. 	<ul style="list-style-type: none"> • Do not place heavy objects on the remote control, or step on it. 





When the operation fails with the remote control

- Are the batteries running down?
 "Replacing the batteries" above.
 Replace the batteries with new ones and repeat the operation.

- If the operation still fails, handle as per emergency run operation.
 Page 15
 Contact your dealer.

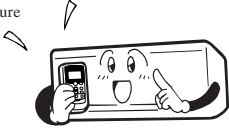
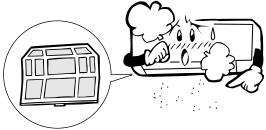
Operating hints

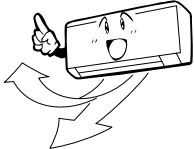
■ Please observe the following for the most economic and comfortable use of your unit.

<p>Set a suitable room temperature. suitable temperature</p>  <p>Excessively low temperatures are not good for your health and waste electricity.</p>	<p>Clean the filters frequently.</p>  <p>Clogged filters may block the air flow and cause less efficient operation.</p>	<p>Avoid direct sunlight and draught.</p>  <p>Cut out direct sunlight by drawing the curtains or blinds when cooling. Keep windows and doors shut, except when ventilating.</p>
<p>Adjust the airflow direction properly.</p>  <p>Adjust the up/down and left/right airflow to ensure a steady room temperature.</p>	<p>Operate the unit only when needed.</p>  <p>Use the timer properly to operate the unit only when needed.</p>	<p>Generate little heat when cooling.</p>  <p>Keep heat sources out of the room as much as possible.</p>

Maintenance

Before maintenance

Turn off the power switch.



• **Don't spill water.**



There's a danger of electric shock.

Wipe the unit with a soft, dry cloth.



- **Do not touch the aluminum fins on the heat exchanger.**
- **Stand firmly on a stepladder or other stable object when removing the inlet panel and filter.**

Don't use the following articles:

- Hot water (40°C or more)
It may deform or discolour the unit.
- Petrol, paint thinner, benzine or polishing agents, etc.
They may deform or scratch the unit.

During the operational season

Cleaning the air filter

Standard interval is once every two week

1 Remove the air filter

- ① Pull up to this side the air inlet panel.
- ② Lightly hold the knobs at both sides and lift a little to remove the panel to this side.

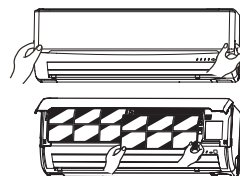

2 Cleaning

If the filter is very dirty, clean it with warm water (approx. 30°C), and dry it thoroughly.

CAUTION

- Don't clean the filters with boiling water.
- Don't dry them over an open flame.
- Pull them out gently.



3 Reinstall the air filter

- Holding firmly the filter at both sides as shown at right and insert securely.
- Operating without putting back the air filters will make the unit dusty, and may cause damage.



Cleaning the unit

- Wipe the unit with a soft, dry cloth, or use a vacuum cleaner.
- If the unit is very dirty, wipe it with a cloth soaked in warm water.

Cleaning the air inlet panel

- Removal, installation of air inlet panel .  Page 6
- The panel can be washed with water. After washing with water, wipe any moisture off the panel and dry out of direct sunlight.

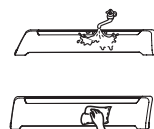

NOTE

Cooling is affected by an air filter clogged up with dust etc., and the operation noise becomes louder. It may also use extra electricity. Please clean the air filter at appropriate intervals.

At the end of the season

- 1** Perform the fan operation for a half day.
Dry the inside of the unit.
- 2** Stop the unit and turn off the power switch.
The unit uses appr. 2W even when the power switch has been turned off during the off-season for safety or for saving energy.
- 3** Clean and reinstall the air filters.
- 4** Clean both the indoor and outdoor units.
- 5** Remove batteries from the remote control.

At the beginning of the season

- 1** Make certain that there are no obstacles blocking the air flow around the air intake and outlet openings of the indoor and outdoor units.
- 2** Check the installation base for corrosion or rust.
- 3** Ensure that nothing has snapped and that the earthed flex is not disconnected.
- 4** Ensure that the air filters are clean.
- 5** Turn on the power switch.
- 6** Insert batteries in the remote control.

Installing, inspecting, and replacing the air-cleaning filter

1. Open the air inlet panel and remove the air filters.
2. Remove the filter holders, with the air-cleaning filter installed in the folders, from the air-conditioner.
3. Remove the natural enzyme filter from filter holder and inspect the filter. Use a vacuum cleaner to remove any dust or dirt from the natural enzyme filter. Replace the natural enzyme filter if it cannot be cleaned or if it has been for about 1 year.
(The natural enzyme filter should be replaced after about 1 year of use. However, the actual replacement period may vary depending on the conditions in which the filter is used.)

Remove the photocatalytic washable deodorizing filter from the filter holder and inspect the filter. Periodically, remove any dust or dirt from the photocatalytic washable deodorizing filter. If the photocatalytic washable deodorizing filter is particularly dirt, it may be washed with water. However, the filter is fragile so be sure to wash it installed in the filter holder to avoid damaging it. After washing the filter, place it in sunlight to dry. Placing the filter in sunlight revitalizes the deodorizing effect.

(Do not dispose of the filter holders. They are reused.)

4. Install the natural enzyme filter and the photocatalytic washable deodorizing filter in the filter holders, and then install the filter holders in the air-conditioner.

NOTE

The natural enzyme filter and the photocatalytic washable deodorizing filter may be installed on either the right or left side of the air-conditioner.

5. Install the air filters and closed the air inlet panel.

For replacement the air-cleaning filter, contact your dealer.

CAUTION

Do not expose natural enzyme filters to direct sunlight for an extended period. The bacteriolytic effect will be lost.

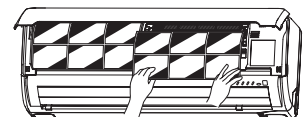
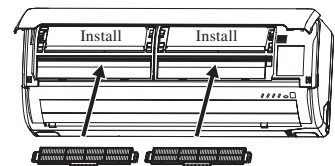
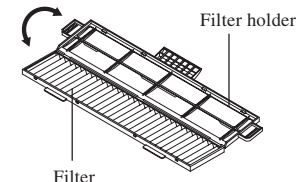
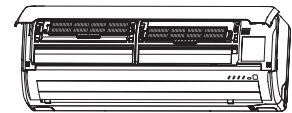
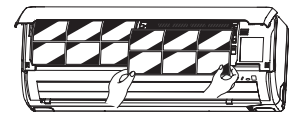

Item	Feature	Color
Natural enzyme filter	By using the work of oxygen, mold and bacteria on the filter are destroyed and the room air is kept clean.	Green
Photocatalytic washable deodorizing filter	Sources of odors on the filter are broken up, resulting in a deodorizing effect.	Orange

Has the unit been installed correctly?

Suitable installation position

- Is there any obstruction in front of the indoor unit, preventing proper ventilation and functioning?
- Don't install the unit in any of the following places:
 - Where there is a danger of leaking inflammable gases.
 - Where there is substantial splashing of oil.
- Malfunctioning due to corrosion may occur if the unit is installed in a spa where sulfide gases are generated, or in a seaside resort exposed to sea breezes. Contact your dealer.
- The air-conditioner and remote control must be at least 1 metre away from a TV set or radio.
- Drain the dehumidified liquid from the indoor unit into a spot that drains well.

Pay attention to operating noises!

- When you install the unit, take care to choose a place that can comfortably stand the weight of the unit and does not increase the operating noise or vibration. If there is any likelihood that vibration may be transmitted through the house, fix the unit with the aid of vibration-proof pads between the unit and the fittings.
- Select a place where cold or hot air and operation noises from the indoor and outdoor units do not cause any inconvenience to your neighbours.
- Do not leave any obstacles near the outlet and inlet of the outdoor unit. This may cause malfunctioning and increased operating noise.
- If you hear an irregular noise during operation, contact your dealer.

Inspection and maintenance

Dependent upon service conditions and operating environment, the inside of the air-conditioner may become dirty after a number of seasons' service (3 to 5 years). This will reduce performance. In addition to normal cleaning, we would recommend inspection and maintenance. (The air-conditioner has a longer life without any trouble.)

- Contact your dealer, or any distributor, for inspection and maintenance. (There will be a charge for this service).
- We would recommend inspection and maintenance to be carried out during the off-season.
- If the supply cord of this appliance is damaged, it must only be replaced by a repair shop appointed by the manufacturer, because special purpose tools are required.

Troubleshooting

Please carry out the following checks before making a service call.

The air-conditioner does not work at all.

Has the power switch been turned off?



Has the timer been set in the "ON" position?



Is there a power failure or a blown fuse?

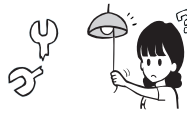

If the air-conditioner does not operate properly after you have checked the left points, or if any doubt still exists after you have consulted page 21, or if things happen as shown on page 22, switch off the power and contact your dealer.

Poor cooling

Have you set the thermostat at a suitable temperature?



Is the air filter clean? (Not clogged?)



Did you leave any doors or windows open?

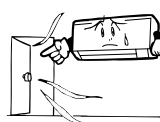

Is there any direct sunlight entering the room?





Is there a heat source in the room?



Are there too many people in the room?

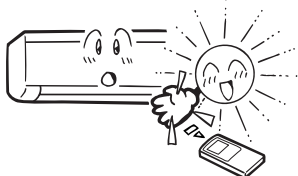

Please remember!

<p>You cannot restart the unit immediately after you have stopped it.</p> <p>(RUN light is on)</p> 	<p>Restarting has been blocked for 3 minutes after you have stopped or after switching off the power during operation, to protect the unit.</p>  <p>The three-minute protection timer in the microcomputer automatically starts up again.</p>
<p>Air is not blown out when starting the DRY operation.</p> <p>(RUN light is on)</p>	<p>The indoor fan may stop to prevent re-evaporation of dehumidified moisture and to save energy.</p>
<p>Some steam escapes during COOL operation.</p>	<p>This may occur if the room's temperature and humidity are very high. It disappears as soon as the temperature and humidity decrease.</p>
<p>There is a slight smell.</p>	<p>Air blown out during operation may smell. This is caused by tobacco or cosmetics sticking to the unit.</p>
<p>You hear a slight gurgling sound.</p> 	<p>This is caused by refrigerating liquid moving within the unit.</p>
<p>You hear a slight cracking sound.</p>	<p>This is caused by heat expansion or contraction.</p>
<p>You hear a hissing or clicking sound.</p>	<p>This is caused by the operation of the refrigerant control valves or electric components.</p>
<p>After a power cut, you cannot re-start, even if power has been restored, unless you have the power blackout auto restart function.</p>	<p>The memory circuit of the microcomputer has been wiped out. Use the remote control to start the operation again.</p>
<p>Remote control signals are not received.</p>	<p>Remote control signals may not be received if the signal receiver on the air-conditioner is exposed to direct sunlight or other bright light. If so, cut out the sunlight or reduce the other light.</p> 
<p>Moisture may form on the air outlet grills.</p>	<p>If the unit is operated for a long time in high humidity, moisture may form on the air outlet grills and start dripping.</p>

When to contact your distributor without delay

■ Turn off the power switch immediately and inform your dealer in any of the following situations:

The fuse or switch blows continuously.



The cable becomes extremely hot.
The covering of the cable is cracked.

⚠ CAUTION

If the power cord becomes damaged, ask your dealer or a qualified engineer to install the replacement to avoid accidents.

The TV, radio or other equipment starts to malfunction.

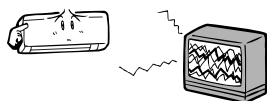

A switch does not activate properly.

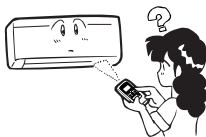

You hear a strange noise during operation.



When faulty movement is observed when the ON/OFF button is pressed, even after turning off the power switch and restarting the operation after 3 minutes, the faulty movement does not disappear.



The RUN and TIMER lights on the unit indication section blink quickly (0.5 sec. ON; 0.5 sec. OFF) and don't work.

Self diagnosis function

■ We are constantly trying to do better service to our customers by installing such judges that show abnormality of each function as follows:

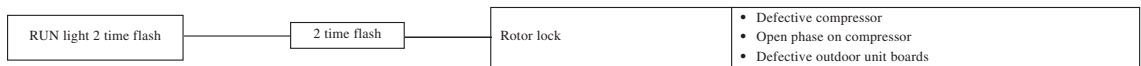
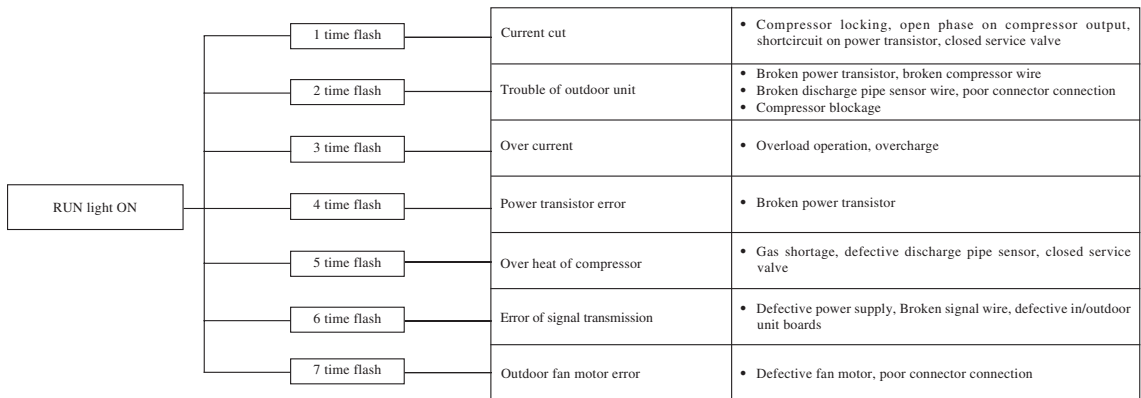
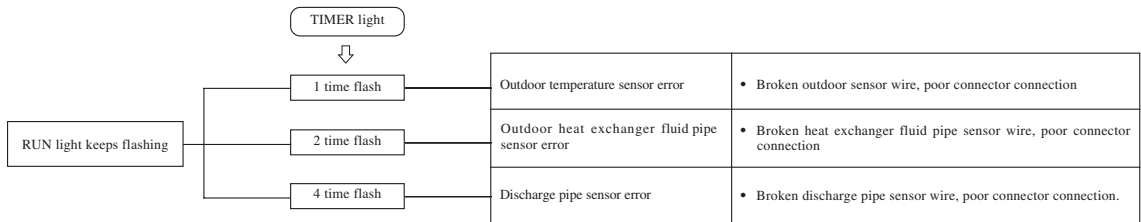
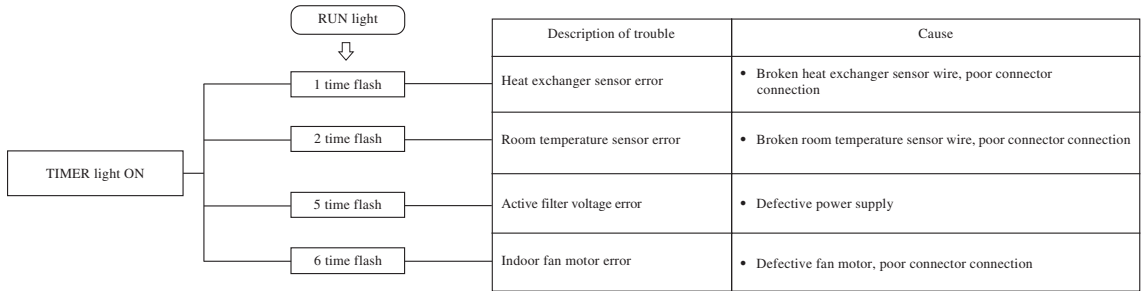



INSTALLATION DIRECTIONS

Contents

Safety precautions	26
Selection of installation location	28
Installation of indoor unit	29
Installation of outdoor unit	32
Connection of refrigerant pipings	32
How to relocate or dispose of the unit	33
Installation of remote control switch	34
Earthing work	34
Trial run and operation	34
Installations test check points	34

Safety precautions

- When install the unit, be sure to check whether the selection of installation place, power supply specifications, usage limitation (piping length, height differences between indoor and outdoor units, power supply voltage and etc.) and installation spaces.
- We recommend you to read this “SAFETY PRECAUTIONS” carefully before the installation work in order to gain full advantage of the functions of the unit and to avoid malfunction due to mishandling.
- The precautions described below are divided into **⚠WARNING** and **⚠CAUTION**. The matters with possibilities leading to serious consequences such as death or serious personal injury due to erroneous handling are listed in the **⚠WARNING** and the matters with possibilities leading to personal injury or damage of the unit due to erroneous handling including probability leading to serious consequences in some cases are listed in **⚠CAUTION**. These are very important precautions for safety. Be sure to observe all of them without fail.
- Be sure to confirm no anomaly on the equipment by commissioning after completed installation and explain the operating methods as well as the maintenance methods of this equipment to the user according to the owner’s manual.
- Keep the installation manual together with owner’s manual at a place where any user can read at any time. Moreover if necessary, ask to hand them to a new user.
- For installing qualified personnel, take precautions in respect to themselves by using suitable protective clothing, groves, etc., and then perform the installation works.
- Please pay attention not to fall down the tools, etc. when installing the unit at the high position.
- If unusual noise can be heard during operation, consult the dealer.
- Symbols which appear frequently in the text have the following meaning:

	Observe instructions with great care		Strictly prohibited		Provide proper earthing
---	--------------------------------------	---	---------------------	---	-------------------------

WARNING

	<ul style="list-style-type: none"> • Installation must be carried out by the qualified installer. If you install the system by yourself, it may cause serious trouble such as water leaks, electric shocks, fire and personal injury, as a result of a system malfunction. • Install the system in full accordance with the instruction manual. Incorrect installation may cause bursts, personal injury, water leaks, electric shocks and fire. • Be sure to use only for household and residence. If this appliance is installed in inferior environment such as machine shop and etc., it can cause malfunction. • Use the original accessories and the specified components for installation. If parts other than those prescribed by us are used, it may cause water leaks, electric shocks, fire and personal injury. • Install the unit in a location with good support. Unsuitable installation locations can cause the unit to fall and cause material damage and personal injury. • Ensure the unit is stable when installed, so that it can withstand earthquakes and strong winds. Unsuitable installation locations can cause the unit to fall and cause material damage and personal injury. • Ventilate the working area well in the event of refrigerant leakage during installation. If the refrigerant comes into contact with naked flames, poisonous gas is produced. • When installing in small rooms, take prevention measures not to exceed the density limit of refrigerant in the event of leakage. Consult the expert about prevention measures. If the density of refrigerant exceeds the limit in the event of leakage, lack of oxygen can occur, which can cause serious accidents. • After completed installation, check that no refrigerant leaks from the system. If refrigerant leaks into the room and comes into contact with an oven or other hot surface, poisonous gas is produced. • Use the prescribed pipes, flare nuts and tools for R410A. Using existing parts (for R22 or R407C) can cause the unit failure and serious accidents due to burst of the refrigerant circuit. • Tighten the flare nut by torque wrench with specified method. If the flare nut were tightened with excess torque, this may cause burst and refrigerant leakage after a long period. • Do not open the operation valves for liquid line and gas line until completed refrigerant piping work, air tightness test and evacuation. If the compressor is operated in state of opening operation valves before completed connection of refrigerant piping work, air can be sucked into refrigerant circuit, which can cause burst or personal injury due to anomalously high pressure in the refrigerant. 	<ul style="list-style-type: none"> • The electrical installation must be carried out by the qualified electrician in accordance with “the norm for electrical work” and “national wiring regulation”, and the system must be connected to the dedicated circuit. Power supply with insufficient capacity and incorrect function done by improper work can cause electric shocks and fire. • Be sure to shut off the power before starting electrical work. Failure to shut off the power can cause electric shocks, unit failure or incorrect function of equipment. • Be sure to use the cables conformed to safety standard and cable ampacity for power distribution work. Unconformable cables can cause electric leak, anomalous heat production or fire. • This appliance must be connected to main power supply by means of a circuit breaker or switch (fuse:16A) with a contact separation of at least 3mm. • When plugging this appliance, a plug conforming to the norm IEC60884-1 must be used. • Use the prescribed cables for electrical connection, tighten the cables securely in terminal block and relieve the cables correctly to prevent overloading the terminal blocks. Loose connections or cable mountings can cause anomalous heat production or fire. • Arrange the wiring in the control box so that it cannot be pushed up further into the box. Install the service panel correctly. Incorrect installation may result in overheating and fire. • Be sure to fix up the service panels. Incorrect fixing can cause electric shocks or fire due to intrusion of dust or water. • Be sure to switch off the power supply in the event of installation, inspection or servicing. If the power supply is not shut off, there is a risk of electric shocks, unit failure or personal injury due to the unexpected start of fan. • Stop the compressor before disconnecting refrigerant pipes in case of pump down operation. If disconnecting refrigerant pipes in state of opening operation valves before compressor stopping, air can be sucked, which can cause burst or personal injury due to anomalously high pressure in the refrigerant circuit. • Only use prescribed optional parts. The installation must be carried out by the qualified installer. If you install the system by yourself, it can cause serious trouble such as water leaks, electric shocks, fire.
	<ul style="list-style-type: none"> • Do not put the drainage pipe directly into drainage channels where poisonous gases such as sulphide gas can occur. Poisonous gases will flow into the room through drainage pipe and seriously affect the user’s health and safety. • Ensure that no air enters in the refrigerant circuit when the unit is installed and removed. If air enters in the refrigerant circuit, the pressure in the refrigerant circuit becomes too high, which can cause burst and personal injury. • Do not processing, splice the power cord, or share a socket with other power plugs. This may cause fire or electric shock due to defecting contact, defecting insulation and over-current etc. 	<ul style="list-style-type: none"> • Do not bundling, winding or processing for the power cord. Or, do not deforming the power plug due to treat it. This may cause fire or heating. • Do not vent R410A into the atmosphere : R410A is a fluorinated greenhouse gas, covered by the Kyoto Protocol with Global Warming Potential (GWP)=1975. • Do not run the unit with removed panels or protections. Touching rotating equipments, hot surfaces or high voltage parts can cause personal injury due to entrapment, burn or electric shocks. • Do not perform any change of protective device itself or its setup condition. The forced operation by short-circuiting protective device of pressure switch and temperature controller or the use of non specified component can cause fire or burst.
	<ul style="list-style-type: none"> • Carry out the electrical work for ground lead with care. Do not connect the ground lead to the gas line, water line, lightning conductor or telephone line’s ground lead. Incorrect grounding can cause unit faults such as electric shocks due to short-circuiting. 	

⚠ CAUTION



- **Use the circuit breaker with sufficient breaking capacity.**
If the breaker does not have sufficient breaking capacity, it can cause the unit malfunction and fire.
- **Earth leakage breaker must be installed.**
If the earth leakage breaker is not installed, it can cause electric shocks.
- **Install isolator or disconnect switch on the power supply wiring in accordance with the local codes and regulations.**
- **Be sure to install indoor unit properly according to the instruction manual in order to run off the drainage smoothly.**
Improper installation of indoor unit can cause dropping water into the room and damaging personal property.
- **Install the drainage pipe to run off drainage securely according to the installation manual.**
Incorrect installation of the drainage pipe can cause dropping water into the room and damaging personal property.
- **Be sure to install the drainage pipe with descending slope of 1/100 or more, and not to make traps and air-bleedings.**
Check if the drainage runs off securely during commissioning and ensure the space for inspection and maintenance.
- **After maintenance, all wiring, wiring ties and the like, should be returned to their original state and wiring route, and the necessary clearance from all metal parts should be secured.**
- **Secure a space for installation, inspection and maintenance specified in the manual.**
Insufficient space can result in accident such as personal injury due to falling from the installation place.

- **Take care when carrying the unit by hand.**
If the unit weighs more than 20kg, it must be carried by two or more persons. Do not carry by the plastic straps, always use the carry handle when carrying the unit by hand. Use gloves to minimize the risk of cuts by the aluminum fins.
- **Dispose of any packing materials correctly.**
Any remaining packing materials can cause personal injury as it contains nails and wood. And to avoid danger of suffocation, be sure to keep the plastic wrapper away from children and to dispose after tear it up.
- **For installation work, be careful not to get injured with the heat exchanger, piping flare portion or screws etc.**
- **Be sure to insulate the refrigerant pipes so as not to condense the ambient air moisture on them.**
Insufficient insulation can cause condensation, which can lead to moisture damage on the ceiling, floor, furniture and any other valuables.
- **When perform the air conditioner operation (cooling or drying operation) in which ventilator is installed in the room. In this case, using the air conditioner in parallel with the ventilator, there is the possibility that drain water may backflow in accordance with the room lapse into the negative pressure status. Therefore, set up the opening port such as incorporate the air into the room that may appropriate to ventilation (For example: Open the door a little). In addition, just as above, so set up the opening port if the room lapse into negative pressure status due to register of the wind for the high rise apartment etc.**



- **Do not install the unit in the locations listed below.**
 - Locations where carbon fiber, metal powder or any powder is floating.
 - Locations where any substances that can affect the unit such as sulphide gas, chloride gas, acid and alkaline can occur.
 - Vehicles and ships.
 - Locations where cosmetic or special sprays are often used.
 - Locations with direct exposure of oil mist and steam such as kitchen and machine plant.
 - Locations where any machines which generate high frequency harmonics are used.
 - Locations with salty atmospheres such as coastlines.
 - Locations with heavy snow (If installed, be sure to provide base flame and snow hood mentioned in the manual).
 - Locations where the unit is exposed to chimney smoke.
 - Locations at high altitude (more than 1000m high).
 - Locations with ammoniac atmospheres.
 - Locations where heat radiation from other heat source can affect the unit.
 - Locations without good air circulation.
 - Locations with any obstacles which can prevent inlet and outlet air of the unit.
 - Locations where short circuit of air can occur (in case of multiple units installation).
 - Locations where strong air blows against the air outlet of outdoor unit. It can cause remarkable decrease in performance, corrosion and damage of components, malfunction and fire.
- **Do not install the indoor unit in the locations listed below (Be sure to install the indoor unit according to the installation manual for each model because each indoor unit has each limitation).**
 - Locations with any obstacles which can prevent inlet and outlet air of the unit.
 - Locations where vibration can be amplified due to insufficient strength of structure.
 - Locations where the infrared receiver is exposed to the direct sunlight or the strong light beam (in case of the infrared specification unit).
 - Locations where an equipment affected by high harmonics is placed (TV set or radio receiver is placed within 1m).
 - Locations where drainage cannot run off safely. It can affect performance or function and etc.
- **Do not install the outdoor unit in the locations listed below.**
 - Locations where discharged hot air or operating sound of the outdoor unit can bother neighborhood.
 - Locations where outlet air of the outdoor unit blows directly to plants.
 - Locations where vibration can be amplified and transmitted due to insufficient strength of structure.
 - Locations where vibration and operation sound generated by the outdoor unit can affect seriously (on the wall or at the place near bed room).
 - Locations where an equipment affected by high harmonics is placed (TV set or radio receiver is placed within 1m).
 - Locations where drainage cannot run off safely. It can affect surrounding environment and cause a claim.

- **Do not install the unit near the location where leakage of combustible gases can occur.**
If leaked gases accumulate around the unit, it can cause fire.
- **Do not install the unit where corrosive gas (such as sulfuric acid gas etc.) or combustible gas (such as thinner and petroleum gases) can accumulate or collect, or where volatile combustible substances are handled.**
Corrosive gas can cause corrosion of heat exchanger, breakage of plastic parts and etc. And combustible gas can cause fire.
- **Do not use the indoor unit at the place where water splashes may occur such as in laundries.**
Since the indoor unit is not waterproof, it can cause electric shocks and fire.
- **Do not install nor use the system close to the equipment that generates electromagnetic fields or high frequency harmonics.**
Equipment such as inverters, standby generators, medical high frequency equipments and telecommunication equipments can affect the system, and cause malfunctions and breakdowns. The system can also affect medical equipment and telecommunication equipment, and obstruct its function or cause jamming.
- **Do not place any variables which will be damaged by getting wet under the indoor unit.**
When the relative humidity is higher than 80% or drainage pipe is clogged, condensation or drainage water can drop and it can cause the damage of valuables.
- **Do not install the remote control at the direct sunlight.**
It can cause malfunction or deformation of the remote control.
- **Do not use the unit for special purposes such as storing foods, cooling precision instruments and preservation of animals, plants or art.**
It can cause the damage of the items.
- **Do not install the outdoor unit in a location where insects and small animals can inhabit.**
Insects and small animals can enter the electric parts and cause damage or fire. Instruct the user to keep the surroundings clean.
- **Do not use the base flame for outdoor unit which is corroded or damaged due to long periods of operation.**
Using an old and damage base flame can cause the unit falling down and cause personal injury.
- **Do not use any materials other than a fuse with the correct rating in the location where fuses are to be used.**
Connecting the circuit with copper wire or other metal thread can cause unit failure and fire.
- **Do not touch any buttons with wet hands.**
It can cause electric shocks.
- **Do not touch any refrigerant pipes with your hands when the system is in operation.**
During operation the refrigerant pipes become extremely hot or extremely cold depending the operating condition, and it can cause burn injury or frost injury.
- **Do not touch the suction or aluminum fin on the outdoor unit.**
This may cause injury.
- **Do not put anything on the outdoor unit and operating unit.**
This may cause damage the objects or injury due to falling to the object.

Standard accessories (Installation kit) Accessories for indoor unit		Q'ty
①	Installation board (Attached to the rear of the indoor unit)	1
②	Wireless remote control	1
③	Remote control holder	1
④	Tapping screws (for installation board 4dia. by 25mm)	4
⑤	Wood screw (for remote control switch holder 3.5dia. by 16mm)	2
⑥	Battery [R03 (AAA, Micro) 1.5V]	2
⑦	Air-cleaning filters	2
⑧	Filter holders (Attached to the front panel of the indoor unit)	2

Option parts		Q'ty
Ⓐ	Sealing plate	1
Ⓑ	Sleeve	1
Ⓒ	Inclination plate	1
Ⓓ	Putty	1
Ⓔ	Drain hose (extension hose)	1
Ⓕ	Piping cover (for insulation of connection piping)	1

Necessary tools for the installation work	
1	Plus headed driver (Phillips screwdriver)
2	Knife
3	Saw
4	Tape measure
5	Hammer
6	Spanner wrench
7	Torque wrench (14.0 ~ 62.0N · m (1.4 ~ 6.2kgf · m))
8	Hole core drill (65mm in diameter)
9	Wrench key (Hexagon) [4m/m]
10	Vacuum pump
11	Vacuum pump adapter (Anti-reverse flow type) (Designed specifically for R410A)
12	Gauge manifold (Designed specifically for R410A)
13	Change hose (Designed specifically for R410A)
14	Flaring tool set (Designed specifically for R410A)
15	Gas leak detector (Designed specifically for R410A)
16	Gauge for projection adjustment (Used when flare is made by using conventional flare tool)
17	Pipe bender

Selection of installation location

INDOOR UNIT

- Where there is no obstructions to the air flow and where the cooled air can be evenly distributed.
- A solid place where the unit or the wall will not vibrate.
- A place where there will be enough space for servicing. (Where space mentioned right can be secured)
- Where wiring and the piping work will be easy to conduct.
- The place where receiving part is not exposed to the direct rays of the sun or the strong rays of the street lighting.
- A place where it can be easily drained.
- A place separated at least 1m away from the television or the radio.
(To prevent interference to images and sounds.)

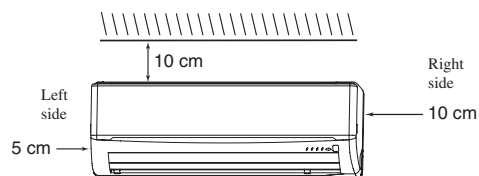

OUTDOOR UNIT

- A place where good air circulation can be obtained and where rain, snow or sunshine will not directly strike the unit.
- A place where discharged hot air or unit's operating sound will not be a nuisance to the neighborhood.
- A place where servicing space can be secured.
- A place where vibration will not be enlarged.

*Avoid installing in the following places.

- A place near the bedroom and the like, so that the operation noise will cause no trouble.
 - A place where there is possibility of flammable gas leakage.
 - A place exposed to strong wind.
- Blowing out port and suction port on the back side of the unit can be installed at a distance of 10cm from walls.
(In case the barrier is 1.2m or above in height, or is overhead, the sufficient space between the unit and wall shall be secured.)
 - When the unit is installed, the space of the following dimension and above shall be secured.

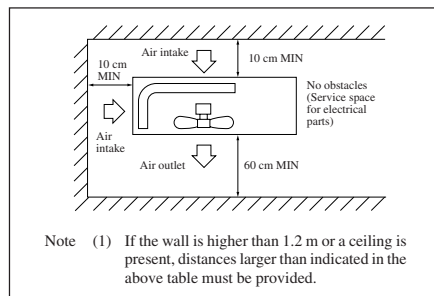

Limitations for one way piping length and vertical height difference

Item	Model	SRK10YL-S	SRK18YL-S
		SRK13YL-S	
Total one way piping length (ℓ)		Max. 15 m	Max. 25 m
Vertical height difference (h)		Max. 10 m	Max. 15 m

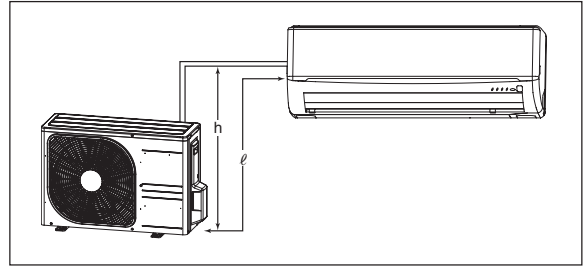

Installation of indoor unit

Installation of installation board

Look for the inside wall structures (Intermediate support or pillar and finally install the unit after level surface has been checked.)

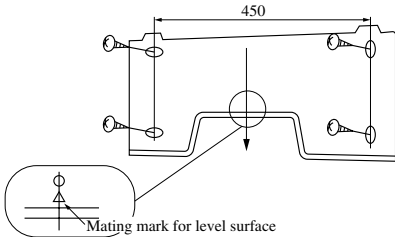

- Adjustment of the installation board in the horizontal direction is to be conducted with four screws in a temporary tightened state.

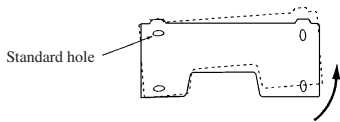

- Adjust so that board will be level by turning the board with the standard hole as the center.

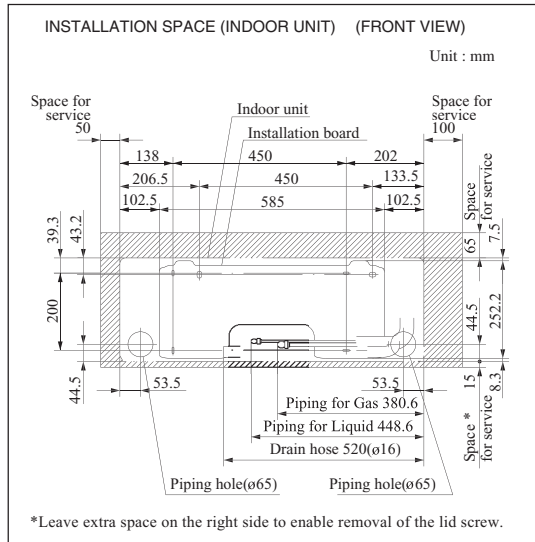

Drilling of holes and fixture sleeve (Option parts)

Drill a hole with $\phi 65$ whole core drill

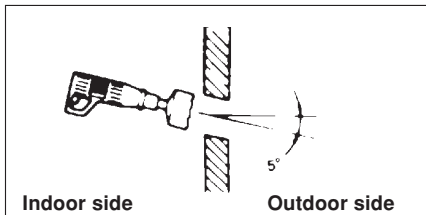

Note (1) Drill a hole with incline of 5 degree from indoor side to outdoor side.

Adjusting sleeve length

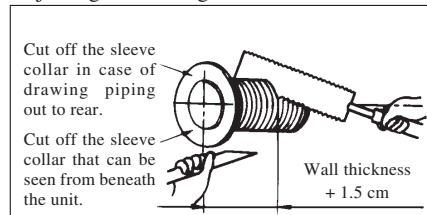

Install the sleeve

(Inserting sleeve)

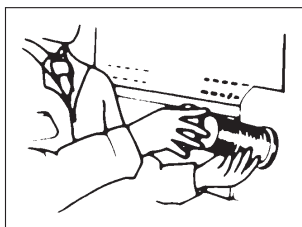

(*Sleeve + *Inclined + *Sealing plate)

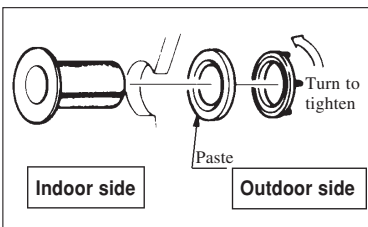

View of sleeve when installed

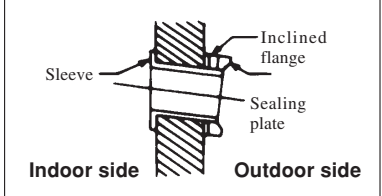

Preparation of indoor unit

① Mounting of connecting wires

- a Remove the lid.
- b Remove the wiring clamp.
- c Connect the connecting wire securely to the terminal block.

Use cable for interconnection wiring to avoid loosening of the wires.

CENELEC code for cables Required field cables.

H05RNR3G1.5 (Example) or 245IEC57

- H Harmonized cable type
- 05 300/500 volts
- R Natural-and/or synth. rubber wire insulation
- N Polychloroprene rubber conductors insulation
- R Standed core
- 4or5 Number of conductors
- G One conductor of the cables is the earth conductor (yellow/green)
- 1.5 Section of copper wire (mm²)

- Connect the connection wire securely to the terminal block. If the wire is not affixed completely, contact will be poor, and it is dangerous as the terminal block may heat up and catch fire.
 - Take care not to confuse the terminal numbers for indoor and outdoor connections.
 - Earth lead wire shall be longer than the other lead wires for the electrical safety in case of the slipping out of the cord from the anchorage.
 - The earth line of power cord must be properly earthed.
 - Affix the connection wire using the wiring clamp.
- d Fix the connecting wire by wiring clamp.
 - e Attach the lid.
 - f Close the air inlet panel.

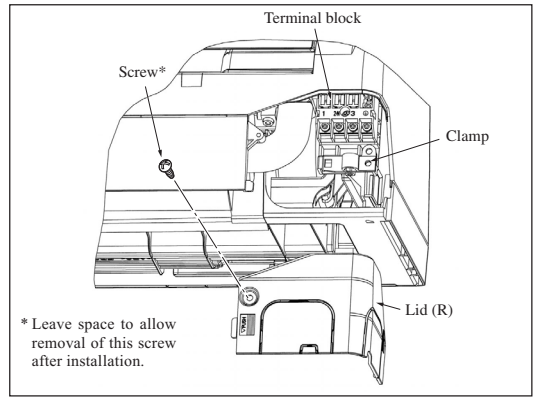

② Shaping the pipe

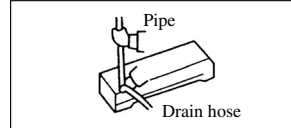

- Hold the bottom of the pipe and change its direction before stretching it and shaping it.

③ Taping of the exterior

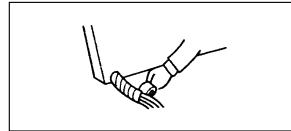

- Tape only the portion that runs through the wall. Always tape the crossover wires with the pipe.

④ Cautions when piping from the left and the rear center of the unit

[Top View]

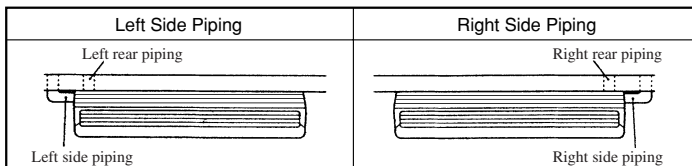

Piping is possible in the rear, left, left rear, left downward, right or downward direction.

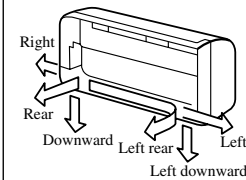

[Drain hose changing procedures]

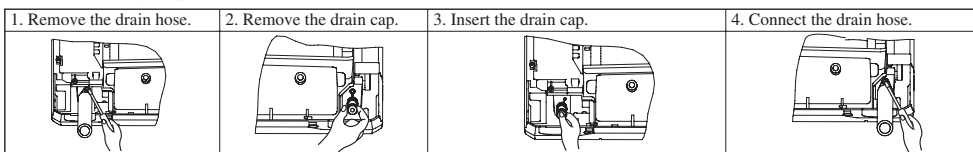

- Remove the screw and drain hose, making it rotate.
- Remove it with hand or pliers.
- Insert the drain cap which was removed at procedure "2" securely using a hexagonal wrench etc. Note: Be careful that If it is not inserted securely, water leakage may occur.
- Insert the drain hose securely, making rotate. And install the screw. Note: Be careful that If it is not inserted securely, water leakage may occur.
- Do not place the power supply cords above the gutter, because the air conditioner is structured in a way where condensation on the back side is collected in to the drain pan before drainage.
- Do not make traps in the drain hose line.

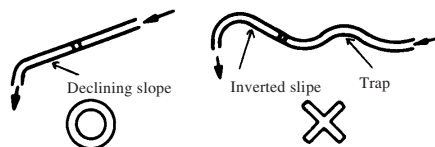
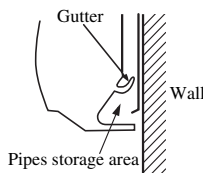

⑤ Securing the indoor unit to the installation board

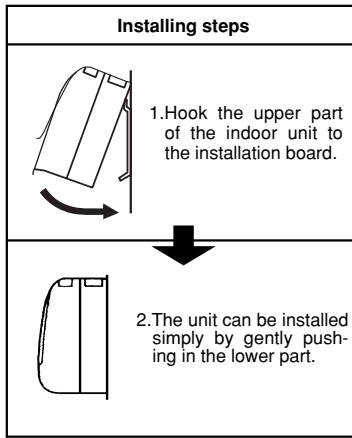
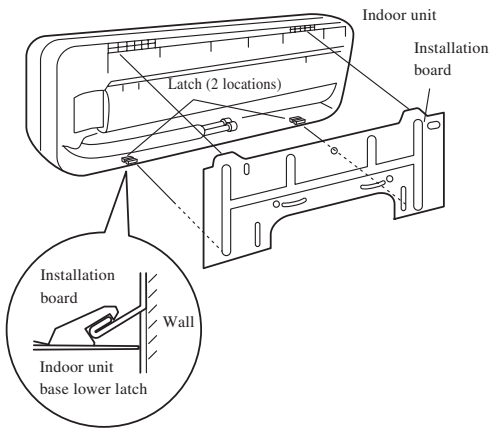

• How to remove the indoor unit from the installation board

- ① Push up at the marked portion of the indoor unit base lower latch, and slightly pull it toward you. (both right and left hand sides)
(The indoor unit base lower latch can be removed from the installation board)
- ② Push up the indoor unit upward. So the indoor unit will be removed from the installation board.

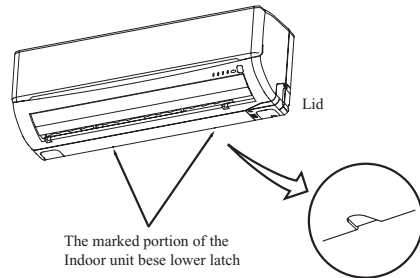

Removal and installation of the front panel

- ① Removing
 - Remove the 2 set screws.
 - Move the lower part of the panel forward and push upwards to remove. (Remove the 3 latches in the upper section.)
- ② Fitting
 - Do remove the air filter.
 - Cover the body with the front panel.
 - Tighten the 2 set screws.
 - Fit the air filter. Carry out in the above order.

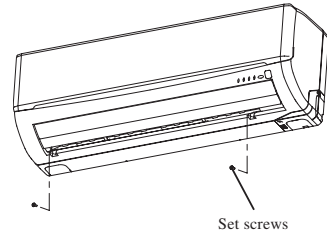

Open/close and detachment/attachment of air inlet panel

- ① To open, pull the panel at both ends of lower part and release latches, then pull up the panel until you feel resistance. (The air inlet panel stops at approx. 60° open position.)
- ② To close, hold the panel at both ends of lower part to lower downward and push it slightly until the latch works, then push the center portion slightly.
- ③ To remove, pull up the panel to the position shown in right illustration and pull it toward you.
- ④ To install, insert the air inlet panel arm into the slot on the front panel from the position shown in right illustration, hold the panel at both ends of lower part, lower it downward slowly, then push it slightly until the latch works and further push the center portion slightly.

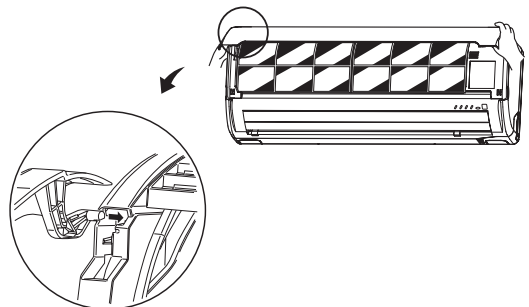

Installation of outdoor unit

- ① Make sure that the unit is stable in installation. Fix the unit to stable base.
- ② When installing the unit at a higher place or where it could be toppled by strong winds, secure the unit firmly with foundation bolts, wire, etc.
- ③ Perform wiring, making wire terminal numbers conform to terminal numbers of indoor unit terminal block.
- ④ Earth lead wire shall be longer than the other lead wires for the electrical safety in case of the slipping out of the cord from the anchorage.
Connect using ground screw located near ⊕ mark.

(POWER SUPPLY CODE)
CENELEC code for cables requiring fields cables.
H05RNR3G2.5

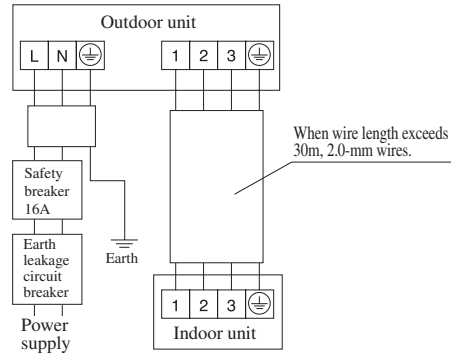

Connection of refrigerant pipings

Preparation

Keep the openings of the pipes covered with tapes etc. to prevent dust, sand, etc. from entering them.

① Indoor unit side

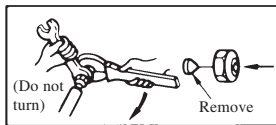

- Remove the flared nuts. (on both liquid and gas sides)

② Outdoor unit side

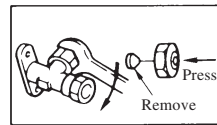

- Remove the flared nuts. (on both liquid and gas sides)

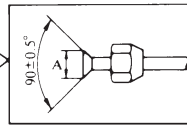

Dimension A
Liquid side (ø6.35): 9.0 dia
Gas side (ø9.52): 13.0 dia
(ø12.7): 16.2 dia

- Install the removed flared nuts to the pipes to be connected, then flare the pipes.

CAUTION
Do not apply refrigerating machine oil to the flared surface.

• Flaring work

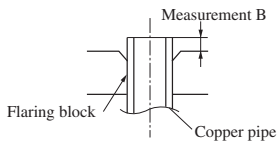

Copper pipe diameter	Measurement B (mm)			Use a flare tool designed for R410A or a conventional flare tool. Please note that measurement B (protrusion from the flaring block) will vary depending on the type of a flare tool in use. If a conventional flare tool is used, please use a copper pipe gauge or a similar instrument to check protrusion so that you can keep measurement B to a correct value.
	Clutch type flare tool f or R410A	Conventional (R22) flare tool		
		Clutch type	Wing nut type	
ø6.35	0.0 ~ 0.5	1.0 ~ 1.5	1.5 ~ 2.0	
ø9.52	0.0 ~ 0.5	1.0 ~ 1.5	1.5 ~ 2.0	
ø12.7	0.0 ~ 0.5	1.0 ~ 1.5	2.0 ~ 2.5	

Connection of refrigerant piping

① Indoor unit side

- Connect firmly gas and liquid side pipings by Torque wrench.

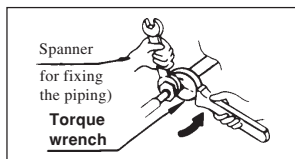

- Specified torquing value:
Liquid side (ø6.35) : 14~18N·m (1.4~1.8kgf·m)
Gas side (ø9.52) : 34~42N·m (3.4~4.2kgf·m)
Gas side (ø12.7) : 49~62N·m (4.9~6.2kgf·m)

- Always use a Torque wrench and back up spanner to tighten the flare nut.

② Outdoor unit side

- Connect firmly gas and liquid side pipings by Torque wrench.

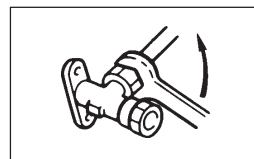

- Specified torquing value:
Liquid side (ø6.35) : 14~18N·m (1.4~1.8kgf·m)
Gas side (ø9.52) : 34~42N·m (3.4~4.2kgf·m)
Gas side (ø12.7) : 49~62N·m (4.9~6.2kgf·m)
- Use one more spanner to fix the valve.

Air purge

- ① Tighten all flare nuts in the pipings both indoor and outside wall so as not to cause leak.
- ② Connect service valve, charge hose, manifold valve and vacuum pump as is illustrated below.
- ③ Open manifold valve handle Lo to its full width, and perform vacuum or evacuation. Continue the vacuum or evacuation operation for 15 minutes or more and check to see that the vacuum gauge reads -0.1 MPa (-76 cmHg).
- ④ After completing vacuum operation, fully open service valve (Both gas and liquid sides) with hexagon headed wrench.
- ⑤ Detach the charge hoses.
- ⑥ Check for possible leakage of gas in the connection parts of both indoor and outdoor.

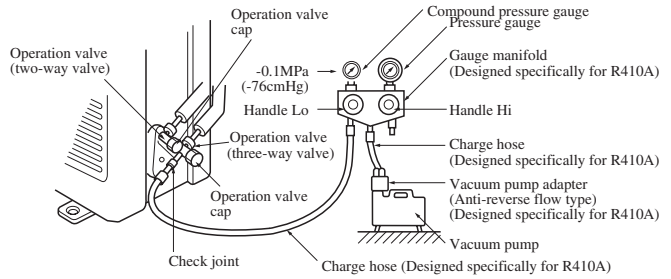

Securely tighten the operation valve cap and the check joint blind nut after adjustment.

Operation valve size (mm)	Operation valve cap tightening torque (N•m)	Check joint blind nut tightening torque (N•m)
$\phi 6.35$ (1/4")	20~30	10~12
$\phi 9.52$ (3/8")		
$\phi 12.7$ (1/2")		

- Since the system uses check joints differing in diameter from those found on the conventional models, a charge hose (for R22) presently in use is not applicable. Please use one designed specifically for R410A.
- Please use an anti-reverse flow type vacuum pump adapter so as to prevent vacuum pump oil from running back into the system. Oil running back into an air-conditioning system may cause the refrigerant cycle to break down.

◆ Additional refrigerant charge

Model	SRK/C10YL-S, 13YL-S	SRK/C18YL-S
Additional refrigerant	Not required	Less than 15m : Not required more than 15m : 20g/m

Insulation of connecting portion

- ① Cover the connection portion of the refrigerant piping with the pipe cover and seal them. If neglecting to do so, moisture occurs on the piping and water will drip out.
- ② Finishing and fixing
 - Ⓐ Tie up the piping with wrapping tape, and shape it so that it conforms to which the pipe is attached.
 - Ⓑ Fix them with clamps as right figure.

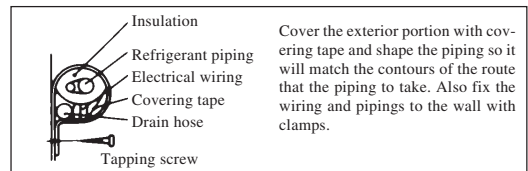
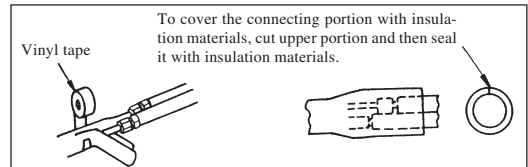

How to relocate or dispose of the unit

- In order to protect the environment, be sure to pump down (recovery of refrigerant).
- Pump down is the method of recovering refrigerant from the indoor unit to the outdoor unit when the pipes are removed from the unit.

<How to pump down>

- ① Connect charge hose to check joint.
- ② Liquid side : Close the liquid valve with hexagon wrench key.
Gas side : Fully open the gas valve.
Carry out cooling operation. (If indoor temperature is low, operate forced cooling operation.)
- ③ After low pressure gauge become 0.01 MPa , stop cooling operation and close the gas valve.

• Forced cooling operation

Turn on a power supply again after a while after turn off a power supply. Then press continually the ON/OFF button 5 seconds or more.

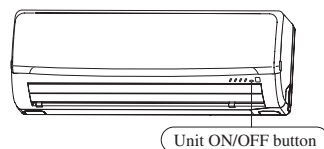

Installation of remote control switch

Mounting method of battery

- Uncover the remote control switch, and mount the batteries [R03(AAA, Micro)×2 pieces] in the body regularly.

(Fit the poles with the indication marks, ⊕ & ⊖ without fail)

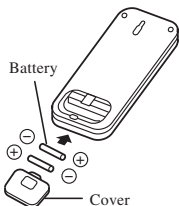

CAUTION

Do not use new and old batteries together.

Fixing to pillar or wall

- Conventionally, operate the wireless remote control by holding in your hand.
- Avoid installing it on a clay wall etc.

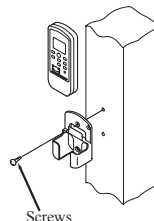

Earthing work

- Earth work shall be carried out without fail in order to prevent electric shock and noise generation.
- The connection of the earth cable to the following substances causes dangerous failures, therefore it shall never be done. City water pipe, Town gas pipe, TV antenna, lightning conductor, telephone line, etc.

Trial run and operation

- ① Conduct trial run after confirming that there is no gas leaks.
- ② When conducting trial run set the remote control thermostat to continuous operation position. However when the power source is cut off or when the unit's operation switch is turned off or was turned to fan operation position, the unit will not go into operation in order to protect the compressor.
- ③ Explain to the customer on the correct usage of the air-conditioner in simple layman's terms.
- ④ Make sure that drain flows properly.

Installations test check points

Check the following points again after completion of the installation, and before turning on the power. Conduct a test run again and ensure that the unit operates properly.

At the same time, explain to the customer how to use the unit and how to take care of the unit following the instruction manual.

After installation

- The power supply voltage is correct as the rating.
- No gas leaks from the joints of the operation valve.
- Operation valve is fully open.
- The pipe joints for indoor and outdoor pipes have been insulated.

Test run

- Air conditioning operation is normal.
- No abnormal noise.
- Water drains smoothly.
- Protective functions are not working.
- The remote control is normal.
- Operation of the unit has been explained to the customer.

(Three-minute restart preventive timer)

When the air conditioner is restarted or when changing the operation, the unit will not start operating for approximately 3 minutes. This is to protect the unit and it is not a malfunction.



AIR-CONDITIONING & REFRIGERATION SYSTEMS

3-1, Asahi, Nishibiwajima-cho, Kiyosu, Aichi, 452-8561, Japan
<http://www.mhi.co.jp>

MITSUBISHI HEAVY INDUSTRIES - MAHAJAK AIR CONDITIONERS CO., LTD.

220 Lad Krabang Industrial Estate Free Zone 3, Soi Chalongsong 31,
Kwang Lamplatiew, Khet Lad Krabang, Bangkok 10520, Thailand
Tel : +66-2-326-0401
Fax : +66-2-326-0419
<http://www.maco.co.th/>

MITSUBISHI HEAVY INDUSTRIES AIR-CONDITIONERS AUSTRALIA, PTY. LTD.

9C Commercial Road Kingsgrove NSW 2208 PO BOX 318 Kingsgrove NSW 1480
Tel : +61-2-8571-7977
Fax : +61-2-8571-7992
<http://www.mhial.com.au>