

WD 5 Premium WD 6 P Premium

English

5

Operating Instructions

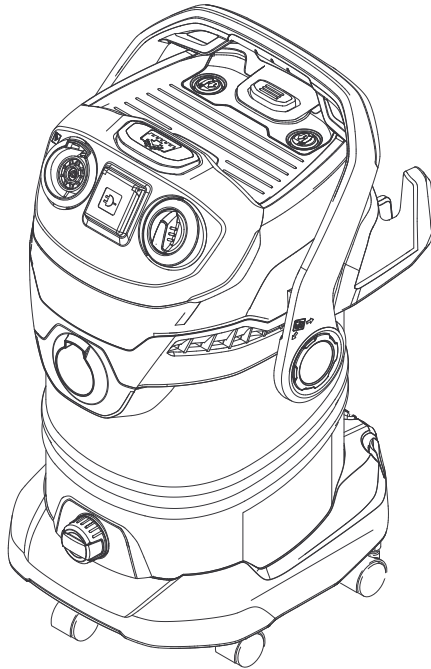

Before first use of the unit
read these operating instructions
and act in accordance with them.



Register and win!
www.kärcher.com/register-and-win

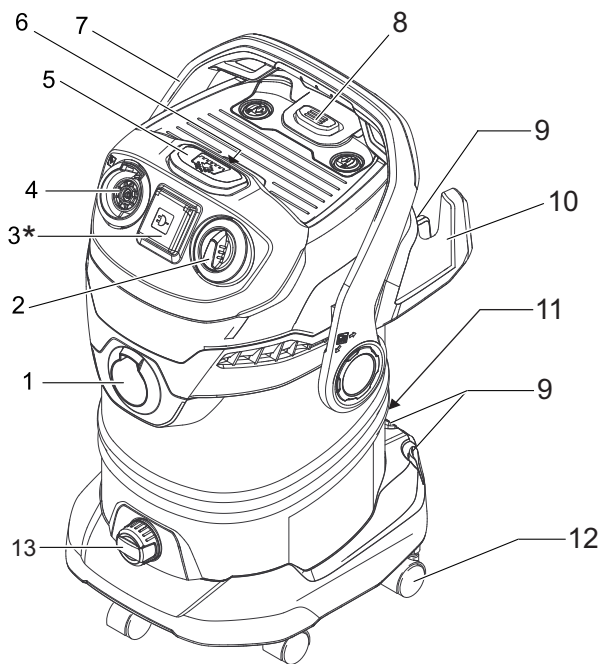

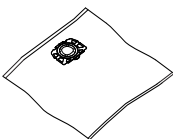
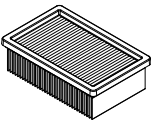
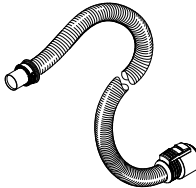
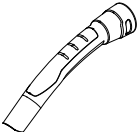
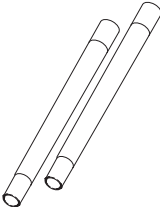
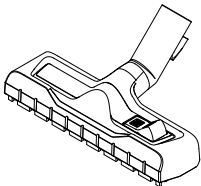
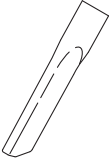

<p>14</p> 	<p>15</p> 	<p>16</p> 
<p>17</p> 	<p>18</p> 	<p>19</p> 
<p>20</p> 	<p>21*</p> 	<p>22*</p> 

* WD 6 P Premium

A 1

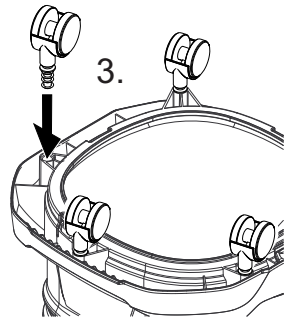
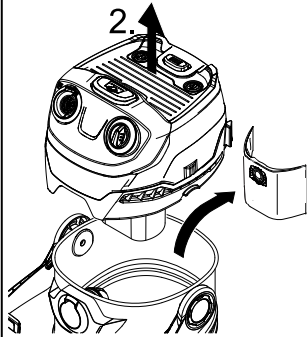
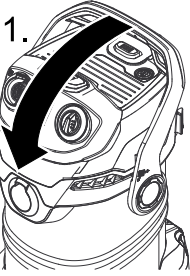

A 1

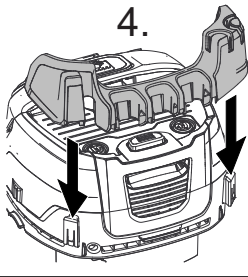

A 2

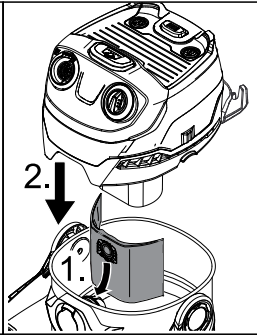
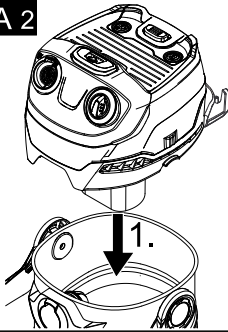

B 1

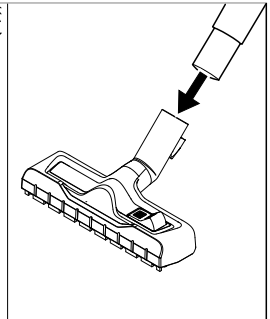
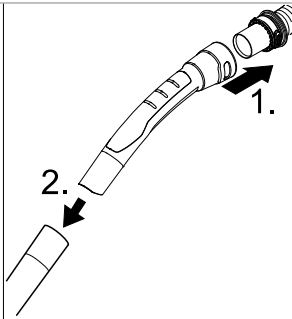
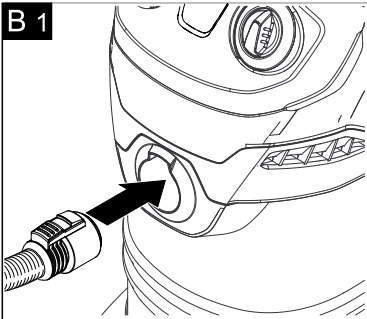

B 2

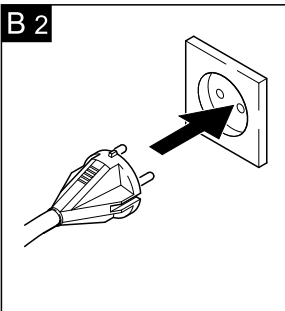

B 3

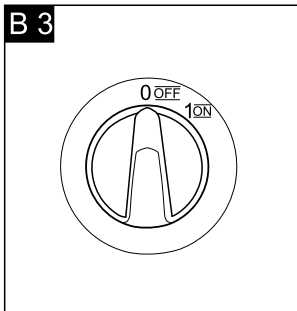

B 4

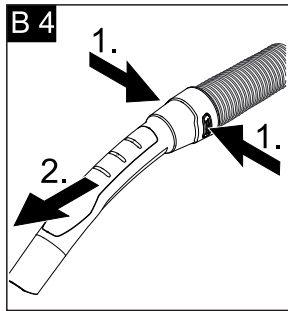

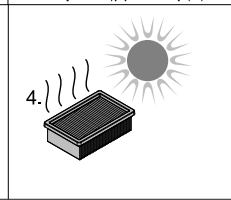
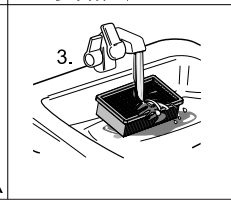
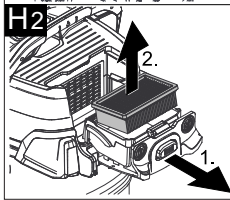
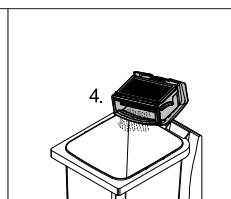
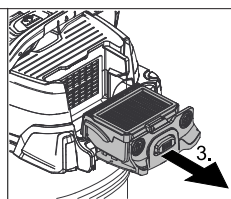
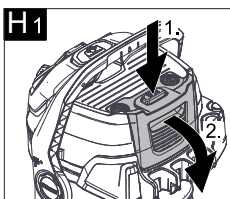
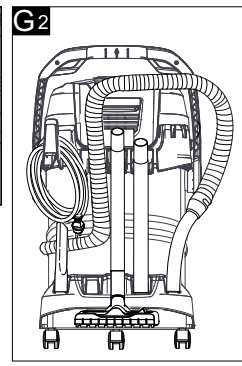
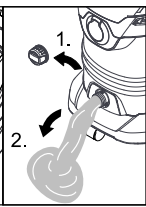
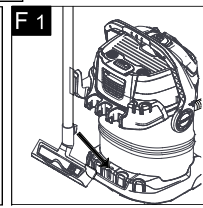
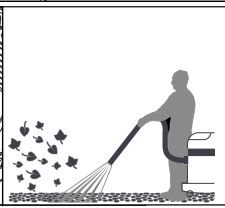
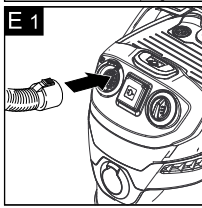
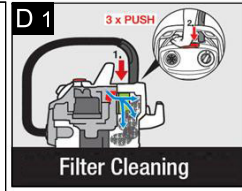
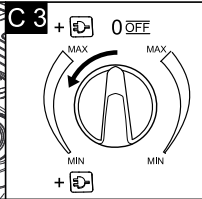
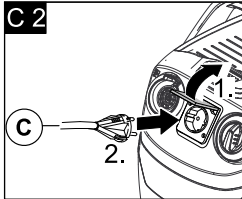
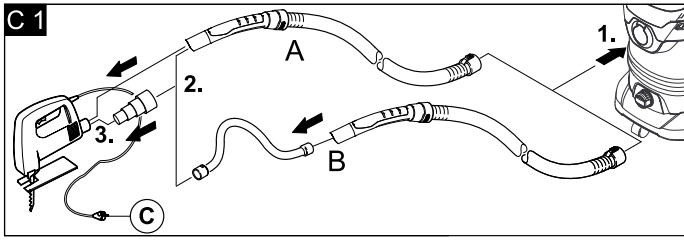

Contents

General notes	EN	5
Safety instructions.	EN	6
Description of the Appliance . .	EN	7
Operation	EN	9
Care and maintenance	EN	11
Troubleshooting	EN	11
Customer Service	EN	11
Technical specifications	EN	12

Dear Customer,



Please read and comply with these original instructions prior to the initial operation of your appliance and store them for later use or subsequent owners.

General notes

Proper use

In accordance with the descriptions and the safety information in these operating instructions the appliance is intended for use as a multi-purpose vacuum cleaner.

This appliance has been designed for use in private households and is not intended for commercial use.

- Protect the unit from rain. Do not store outside.
- This device may not be used to suck in ash and soot.

Use the multi-purpose vacuum cleaner only with:

- Original filter bag.
- Original spare parts, accessories and special accessories.

The manufacturer is not responsible for any damages that may occur on account of improper use or wrong operations.

Environmental protection



The packaging material can be recycled. Please do not place the packaging into the ordinary refuse for disposal, but arrange for the proper recycling.



Old appliances contain valuable materials that can be recycled. Please arrange for the proper recycling of old appliances. Please dispose your old appliances using appropriate collection systems.

Disposing the filters and filter bags

Filters and filter bags are made from environment-friendly materials.

They can therefore be disposed off through the normal household garbage provided you have not sucked in substances that are not permitted to be thrown into household garbage.

Notes about the ingredients (REACH)

You will find current information about the ingredients at:

www.kaercher.com/REACH

Warranty

The terms of the guarantee applicable in each country have been published by our respective national distributors. We will repair possible faults on your unit free of charge within the warranty period, insofar as the faults are caused by material defects or defective workmanship. Guarantee claims should be addressed to your dealer or the nearest authorized customer service centre, and supported by documentary evidence of purchase.

Customer Service

Our KÄRCHER branch will be pleased to help you further in the case of questions or faults.

Ordering spare parts and special attachments

At the end of the operating instructions you will find a selected list of spare parts that are often required.

You can procure the spare parts and the attachments from your dealer or your KÄRCHER branch office.

Safety instructions

- *This appliance is not intended for use by persons with limited physical, sensory or mental capacities or lacking experience and/or skills, unless such persons are accompanied and supervised by a person in charge of their safety or they have received precise instructions on the use of this appliance and have understood the resulting risks.*
- *Children may only use this appliance if they are over the age of 8 and supervised by a person in charge of their safety, or if they have received instructions on the use of this appliance and have understood the resulting risks.*
- *Children must not play with this appliance.*
- *Supervise children to prevent them from playing with the appliance.*
- *Cleaning and user maintenance must not be performed by children without supervision.*
- *Keep packaging film away from children - risk of suffocation!*
- *Switch the appliance off after every use and prior to every cleaning/maintenance procedure.*
- *Risk of fire. Do not vacuum up any burning or glowing objects.*
- *The appliance may not be used in areas where a risk of explosion is present.*

⚠ Electrical connection

The appliance may only be connected to alternating current. The voltage must correspond with the type plate on the appliance.

⚠ Risk of electric shock

Never touch the mains plug and the socket with wet hands.

Do not pull the plug from the socket by pulling on the connecting cable.

Check the power cord with mains plug for damage before every use. To avoid risks, arrange immediately the exchange by an authorized customer service or a skilled electrician, if the power cord is damaged. To avoid accidents due to electrical faults we recommend the use of sockets with a line-side current-limiting circuit breaker (max. 30 mA nominal tripping current).

⚠ WARNING

Certain materials may produce explosive vapours or mixtures when agitated by the suction air!

Never vacuum up the following materials:

- *Explosive or combustible gases, liquids and dust particles (reactive dust particles)*
- *Reactive metal dust particles (such as aluminium, magnesium, zinc) in combination with highly alkaline or acidic detergents*
- *Undiluted, strong acids and alkalis*
- *Organic solvents (such as petrol, paint thinners, acetone, heating oil).*

In addition, these substances may cause the appliance materials to corrode.

Symbols in the operating instructions

⚠ DANGER

Immediate danger that can cause severe injury or even death.

⚠ WARNING

Possible hazardous situation that could lead to severe injury or even death.

⚠ CAUTION

Possible hazardous situation that could lead to mild injury to persons or damage to property.

Description of the Appliance

Illustrations on fold-out page!



- These operating instructions describe the multi-purpose vacuum cleaners listed on the front cover.
- The illustrations show the maximum equipment; depending on the model, there are differences in equipment and supplied accessories.

When unpacking the product, make sure that no accessories are missing and that none of the package contents have been damaged. If you detect any transport damages please contact your dealer.

1 Suction hose connection

Illustration **B 1**

- To connect the suction hose during vacuuming.

2 ON/OFF switch for appliance (without built-in socket)

Illustration **B 3**

- **Position I:** Suction or blowing
- Position 0:** Appliance is switched off

2 ON/OFF switch for appliance (with built-in socket)

Illustration **B 3**

- **Position MAX:** Vacuuming or blowing.
- **Position +  MAX:** Vacuuming with connected electric tool
- Performance regulation: Reduce the suction if necessary during vacuuming, blowing or when working with an electric tool.
- **Position 0:** The appliance is switched off. Electric tool is supplied with voltage.

3 Machine socket

Note: Observe the maximum connected load (see Chapter "Technical data").

Illustration **C 2**

- To connect an electric tool.

4 Blowing connection

Illustration **E 1**

- Connect the suction hose to the blower connection, this will activate the blower function.

5 Filter cleaning button

Illustration **D 1**

- For cleaning the flat pleated filter fitted.

Note: Do not operate the button when the flat pleated filter is wet.

6 Recessed grip

- After unlocking it, grab the appliance head by the handle recess and remove it.

7 Carry handle

Illustration **A 1**

- The carrying handle is also used to lock the appliance head and the container. To unlock, push the bow all the way forward until you clear the lock.
- Grab the appliance head by the handle recess and remove it.

8 Filter box and release key

Illustration **H 1**

Illustration **H 2**

- In order to clean the filter, press the release key, fold out and remove the filter box.

9 Accessory mount

Illustration **G 2**

- The accessories compartment allows the storage of suction pipes and suction nozzles on the appliance.

10 Cable hook

Illustration **G 2**

- To store the mains cable.

11 Parking position

Illustration F 1

→ To rest the floor nozzle during work interruptions.

12 Steering roller

Illustration A 1

→ Turn the container, press in the steering roller in the openings at the base of the container till the end-point.

13 Drain screw

Illustration G 1

→ The drain screw is used to quickly and comfortably empty wastewater in the container. Tilt the container forward for easier emptying.

14 Filter bag

Illustration A 2

Note: Do not use a filter bag for wet vacuuming!

15 Flat fold filter

(already installed in the appliance)

-CAUTION

Always work with an inserted flat fold filter - during wet as well as dry vacuum cleaning!

16 Suction hose with connecting piece

Illustration B 1

→ Push the suction hose into the connection on the appliance, it snaps in place.

→ In order to disconnect it, push down with your thumb and pull the suction hose out.

Note: Accessories, such as suction brushes (optional) can be directly attached to the connecting piece and thus connected to the suction hose.

For convenient working even in tight spaces.

The removable handle can be attached between the accessories and the suction hose if necessary.

See position 17.

Recommendation: In order to vacuum the floor, attach the handle to the suction hose.

17 Removable handle

Illustration B 1

→ Connect the handle with the suction hose until it snaps in place.

Illustration B 4

→ To remove the handle from the suction hose, press the notch using your thumb and pull off the handle.

Note: Due to removing the handle, accessories can be directly attached to the suction hose.

Recommendation: In order to vacuum the floor, attach the handle to the suction hose. See position 16.

18 Suction tubes 2 x 0.5 m

Illustration B 1

→ Put both suction tubes together and connect them with the handle.

19 Floor nozzle

(with switching lever)

Illustration B 1

For convenient switching between dry and wet dirt:

→ For vacuuming dry dirt off the floor, use position with extended brush strips.

→ For vacuuming water off the floor, use position with extended rubber lips.

20 Crevice nozzle

→ For edges, joints, heaters and hard to reach locations.

21 Adapter

Illustration C 1

→ To connect the suction hose with an electric tool

→ Adapt the adapter to the connection diameter of the electric tool using a knife if necessary.

22 Flexible tool hose

Illustration C 1

→ For more flexibility when working with electric tools.

Note: Can also be used with an adapter.

Operation

⚠ CAUTION

Always work with an inserted flat fold filter - during wet as well as dry vacuum cleaning!

Before Startup

Illustration **A 1**

- Remove the appliance head and take the contents out of the container.
- Turn the container, press in the steering roller in the openings at the base of the container till the end-point.
- Insert and lock the appliance head.
- Clip the holder for the accessory compartment onto the rear side of the appliance.

Start up

Illustration **B 1**

- Connect accessories.

Illustration **B 2**

- Plug in the mains plug.

Illustration **B 3**

- Turn on the machine.

Dry vacuum cleaning

⚠ CAUTION

Work with a dry flat fold filter only.

Check the filter for damage prior to installation and replace as necessary.

Illustration **A 2**

- For vacuuming dry dirt an additional filter bag can be inserted if necessary.

⚠ CAUTION

Only operate the filter cleaning without a filter bag inserted, otherwise the filter bag can get damaged.

Information filter bag

- The filling level of the filter bag depends on the dirt that is sucked in.
- The filter bag needs to be replaced more frequently while sucking in fine dust, sand, etc.
- Clogged filter bags can burst - therefore make sure to replace the filter bag in a timely manner!

⚠ CAUTION

Vacuum cold ashes only when using a pre-filter.

Order no. basic design: 2.863-139.0, premium design: 2.863-161.0.

Wet vacuum cleaning

⚠ CAUTION

Immediately switch the appliance off or pull the power plug if foam forms or liquids escape!

Do not use a filter bag!

Note: If the container is full, a float closes the suction opening, and the appliance works at a higher speed. Switch off the appliance immediately, and empty the container.

- For vacuuming up moisture or wetness pay attention to the correct floor nozzle setting and connect the corresponding accessories.

Working with electrical power tools

- Adapt the adapter to the connection diameter of the electric tool using a knife if necessary.

Illustration **C 1**

- **A)** Plug the enclosed adapter onto the handle of the suction hose and connect the electric tool with the connection.
or
- **B)** Use the flexible tool hose to gain more flexibility in your work. Connect this hose to the suction hose and to the adapter and then to the connection of the electric tool.

Illustration **C2**

➔ **For appliances with built-in socket:**

Connect the mains plug of the electric power tool to the vacuum cleaner.

Illustration **C3**

-Switch the appliance on (move the rotary switch to the left to position  MAX) and start working.

Note: As soon as the electric tool is switched on, the suction turbine starts with a 0.5 second delay. If the electric tool is switched off, the suction turbine continues to run for approx. 5 seconds in order to vacuum up the remaining dirt in the suction hose.

Integrated filter cleaning system

The filter cleaning system is intended for vacuuming up large volumes of fine dust without an inserted filter bag.

Note: Thanks to the filter cleaning system the soiled flat pleated filter can be cleaned at the push of the button and the suction performance can be increased again.

Illustration **D1**

➔ Place the handle of the suction hose in the accessory compartment on the appliance head. Push the filter cleaning button 3 x while the appliance is switched on, wait 4 seconds between the individual operations.

Note: After operating the filter cleaning button several times, check the container for its filling volume. Otherwise, the dirt might escape when the container is opened.

Blowing function

Cleaning hard to reach locations or, where vacuuming is not possible, like leaves from a gravel bed.

Illustration **E1**

➔ Connect the suction hose to the blower connection, this will activate the blower function.

Interrupting operation

Illustration **B3**

➔ Turn off the appliance.

Illustration **F1**

➔ Hook the floor nozzle into the parking position.

Finish operation

➔ Turn off the appliance and disconnect the mains plug.

Empty the container

Illustration **G1**

➔ Remove the appliance head and empty the reservoir filled with wet or dry dirt.

For appliances with drain screw:

Empty the dry dirt over the container.

Use the drain screw to empty liquids.

Storing the appliance

Illustration **G2**

➔ Stow away the mains cable and accessory at the machine. Store the appliance in a dry room.

Care and maintenance

⚠ DANGER

Turn off the appliance and remove the mains plug prior to any care and maintenance work.

Repair works may only be performed by the authorised customer service.

⚠ WARNING

Do not use abrasives, glass or universal cleaners! Never immerse the appliance in water.

- Clean the appliance and accessory parts made of plastic with a commercial plastic cleaner.
- If required, rinse the container and accessories with water properly and dry them before reuse.

Clean flat fold filter

Recommendation: Clean the filter box after every use.

Illustration **H1**

- Unlock, fold out and remove the filter cartridge, empty dirt from the filter cartridge over a waste bin.
- In order to clean the inserted flat fold filter, knock the filter box against the edge of the waste bin. It is not necessary to remove the flat fold filter from the filter box.

If necessary, clean the flat fold filter separately.

Illustration **H1**

- Unlock, fold out and remove the filter cartridge.

Illustration **H2**

- Remove the flat fold filter from the filter box and tab it out.
- When necessary, clean under running water only, do not wipe or brush down. Allow to dry completely prior to use.
- Finally, reinstall the dry flat fold filter into the appliance. Insert the filter cartridge into the appliance.

Troubleshooting

Decreasing cleaning power

If the suction power becomes less, check the following points:

- Accessories, suction hose or suction pipes are clogged, please remove the obstruction using a stick.

Illustration **A2**

- Filter bag is full: Insert new filter bag.

Illustration **H2**

- Flat fold filter contaminated: Remove the filter box and clean filter (see Chapter "Cleaning the flat fold filter").
- Replace damaged flat fold filter.

Customer Service

Australia

KÄRCHER Pty. Ltd.
40 Koornang Road
Scoresby, Victoria 3179

1800 675 714 (Free Call)
www.karcher.com.au

New Zealand

Karcher Ltd.
66 Allens Road,
East Tamaki, Auckland

(09) 274-4603
www.karcher.co.nz

Technical specifications

	WD 5 Premium	WD 6 P Premium	
Mains voltage	220 - 240	220 - 240	V
Frequency	1~50-60	1~50-60	Hz
Output P _{nom}	1100	1300	W
Max. connection output of appliance socket	-	1000	W
Mains fuse (slow-blow)	10	10	A
Container capacity	30	30	l
Water intake with handle	15	20	l
Water intake with floor nozzle	13	18	l
Power cord	H 05VV-F2x0,75	H 05VV-F3G1,5	
Weight (without accessories)	9,0	9,4	kg
Sound pressure level (EN 60704-2-1)	71	71	dB(A)

Subject to technical modifications!

2.863-000.0

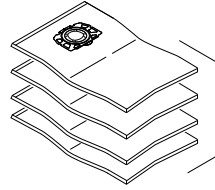
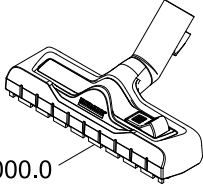

2.863-006.0

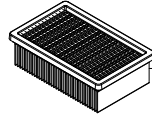

2.863-005.0

4.441-067.0

2.863-012.0

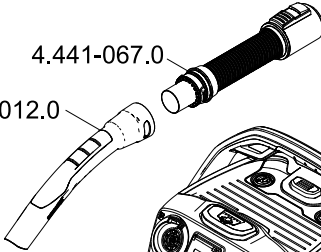

9.084-160.0 *AU WD 5 Premium

6.650-501.0 *AU WD 6 P Premium

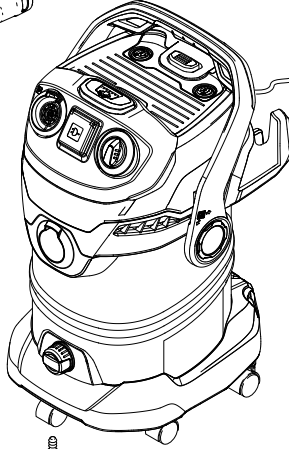
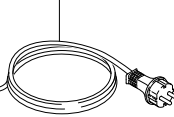

6.900-385.0

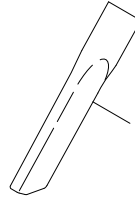

9.036-479.0

9.036-479.0



WD 6 P Premium

9.039-339.0

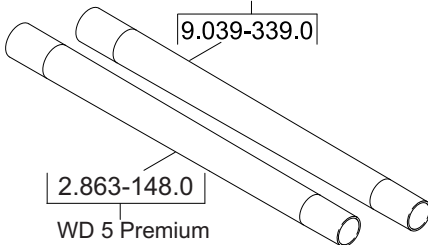

2.863-148.0

WD 5 Premium

2.863-112.0

9.048-061.0

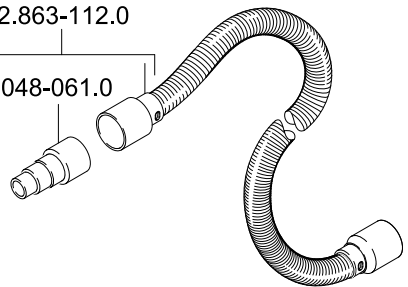

5.965-797.0 01.09.15

KÄRCHER



www.karcher.com.au
www.karcher.co.nz