



# OWNER'S MANUAL MICROWAVE OVEN "CONVECTION"

Please read this owner's manual thoroughly before operating.

MJ3966ASS / MJ3966ABS / MJ3966AWS  
(optional, please check model specification)



MFL69621104

[www.lg.com](http://www.lg.com)

### How the Microwave Function Works

Microwaves are a form of energy similar to radio, television waves, and ordinary daylight. Normally, microwaves spread outwards as they travel through the atmosphere and disappear without effect.

This oven, however, has a magnetron that is designed to make use of the energy in microwaves. Electricity, supplied to the magnetron tube, is used to create microwave energy.

These microwaves enter the cooking area through openings inside the oven. A tray is located inside the oven. Microwaves cannot pass through metal walls of the oven, but they can penetrate such materials as glass, porcelain and paper, the materials out of which microwave-safe cooking dishes are constructed.

Microwaves do not heat cookware, though cooking vessels will eventually get hot from the heat generated by the food.

### A very safe appliance

Your Microwave oven, is one of the safest of all home appliances. When the door is opened, the oven automatically stops producing microwaves. Microwave energy is converted completely to heat when it enters food, leaving no "left over" energy to harm you when you eat your food.

## CONTENTS

### 3 IMPORTANT SAFETY INSTRUCTIONS

---

#### 8 BEFORE USE

---

- 8 Unpacking & Installing
- 10 Control Panel
- 10 Display Icon Meanings
- 11 Setting The Clock
- 11 Quick Start
- 11 More/Less
- 11 Energy Saving

#### 12 HOW TO USE

---

- 12 Manual Cooking (timed cooking)
- 12 Microwave Power Levels
- 13 Grill Cooking
- 13 Grill Combi. Cooking
- 14 Convection Preheat
- 14 Convection Cooking
- 15 Convection Combi. Cooking
- 15 Child Lock
- 16 Inverter Cook
- 16 Defrost & Cook Menu Instructions
- 17 Popular Menu Instructions
- 20 Roast & Bake Menu Instructions
- 22 Healthy Fry / Steam
- 22 Healthy Fry Menu Instructions
- 24 Steam Chef Menu Instructions
- 25 Sensor Cook
- 25 Sensor Cook Menu Instructions
- 27 Slow Cook
- 27 Slow Cook Menu Instructions
- 29 Inverter Defrost
- 29 Inverter Defrost Menu Instructions

#### 30 MICROWAVE-SAFE UTENSILS

---

#### 31 FOOD CHARACTERISTICS & MICROWAVE COOKING

---

#### 33 TO CLEAN YOUR OVEN

---

#### 33 USING THE SMART DIAGNOSIS™ FUNCTION

---

#### 34 QUESTION & ANSWERS

---

#### 35 TECHNICAL SPECIFICATIONS

---

# IMPORTANT SAFETY INSTRUCTIONS

## READ CAREFULLY AND KEEP FOR FUTURE REFERENCE

Read and follow all instructions before using your oven to prevent the risk of fire, electric shock, personal injury, or damage when using the oven. This guide does not cover all possible conditions that may occur.

Always contact your service agent or manufacturer about problems that you do not understand.

### WARNING

This is the safety alert symbol. This symbol alerts you to potential hazards that can cause death or serious injury. All safety messages will follow the safety alert symbol and either the word "WARNING" or "CAUTION". These words mean:

#### WARNING

This symbol will alert you to hazards or unsafe practices which could cause serious bodily harm or death.

#### CAUTION

This symbol will alert you to hazards or unsafe practices which could cause bodily injury or property damage.

### WARNING

- 1 **Do not attempt to tamper with, or make any adjustments or repairs to the door, door seals, control panel, safety interlock switches or any other part of the oven which would involve the removal of any cover protecting against exposure to microwave energy. Do not operate the oven if the door seals and adjacent parts of the microwave oven are faulty. Repairs should only be undertaken by a qualified service technician.**
  - Unlike other appliances, the microwave oven is a high-voltage and a high electrical-current piece of equipment. Improper use or repair could result in harmful exposure to excessive microwave energy or in electric shock.
- 2 **Do not use the oven for the purpose of dehumidification. (ex. Operating the microwave oven with wet newspapers, clothes, toys, electric devices, plants, soil, pets or any other living matter inside it.) The oven must only be used for heating or cooking food.**
  - It can be the cause of serious damage or safety risk such as fire, causing burns or sudden death due to an electric shock.
- 3 **This appliance is not intended for use by persons (including children) with reduced physical, sensory or mental capabilities, or lack of experience and knowledge, unless they have been given supervision or instruction concerning use of the appliance by a person responsible for their safety. (Young) Children should be supervised to ensure that they do not play with the appliance.**
  - Improper use may cause damage such as a fire, electric shock or burn.
- 4 **Accessible parts may become hot during use. Young children should be kept away.**
  - They may be burnt.
- 5 **Liquids and other foods must not be heated in sealed containers since they are liable to explode. Remove the plastic wrapping from food before cooking or defrosting. Note though that in some cases food should be covered with plastic film, for heating or cooking. Never heat baby bottles with the lid or teat still fitted.**
  - Doing so can cause an explosion.
- 6 **Be certain to use proper accessories for each operation mode.**
  - Improper use could result in damage to your oven and accessories, or could cause sparks and fire.
- 7 **Children must not be allowed to play with accessories or hang down from the door or any part of the oven.**
  - Doing so can cause serious injury and damage.

- 8 **I**t is hazardous for anyone other than a competent person to carry out any service or repair operation that involves the removal of a cover which gives protection against exposure to microwave energy.
- 9 **W**hen the appliance is operated in the combination mode (for ovens with Combination function), children should only use the oven under adult supervision due to the temperatures generated.
- 10 **D**o not operate your oven if it is damaged. **I**t is particularly important that the oven door closes properly and that there is no damage to the: (1) door(bent), (2) hinges and latches (broken or loose ), (3) door seals and sealing surfaces.
  - It could result in harmful exposure to excessive microwave energy.
- 11 **I**f the door or door seals are damaged, the oven must not be operated until it has been repaired by a competent person.
- 12 **T**he appliance is supplied from a cord extension set or an electrical portable outlet device, the cord extension set on electrical portable outlet device must be positioned so that it is not subject to splashing or ingress of moisture.
- 13 **O**nly allow children to use the oven without supervision when adequate instructions have been given so that the child is able to use the oven in a safe way and understands the hazards of improper use.
- 14 **T**he appliance and its accessible parts become hot during use. **C**are should be taken to avoid touching heating elements. **C**hildren less than 8 years of age shall be kept away unless continuously supervised.
- 15 **D**uring use the appliance becomes hot. **C**are should be taken to avoid touching heating elements inside the oven.
- 16 **D**o not use harsh abrasive cleaners or sharp metal scrapers to clean the oven door glass since they can scratch the surface, which may result in shattering of the glass

## CAUTION

- 1 **Y**ou cannot operate your oven with the door open due to the safety interlocks built into the door mechanism. **I**t is important not to tamper with the safety interlocks.
  - It could result in harmful exposure to excessive microwave energy. (Safety interlocks automatically switch off any cooking activity when the door is opened.)
- 2 **D**o not place any object (such as kitchen towels, napkins, etc.) between the oven front face and the door or allow food or cleaner residue to accumulate on sealing surfaces.
  - It could result in harmful exposure to excessive microwave energy.
- 3 **P**lease ensure cooking times are correctly set, small amounts of food require shorter cooking or heating times.
  - Over cooking may result in the food catching on fire and subsequent damage to your oven.
- 4 **W**hen heating liquids, e.g. soups, sauces and beverages in your microwave oven,
  - \* **A**void using straight sided containers with narrow necks.
  - \* **D**o not overheat.
  - \* **S**tir the liquid before placing the container in the oven and again halfway through the heating time.
  - \* **A**fter heating, let it stand in the oven for a short time; stir or shake it again carefully and check the temperature of it before consuming to avoid burns (especially, contents of feeding bottles and baby food jars).
  - **B**e careful when handling the container. **M**icrowave heating of beverages can result in delayed eruptive boiling, therefore care must be taken when handling the container.
- 5 **A**n exhaust outlet **w**ill be located on the top, bottom or side of the oven. **D**on't block the outlet.
  - It could result in damage to your oven and poor cooking results.
- 6 **D**o not operate the oven when empty. **I**t is best to leave a glass of water in the oven when not in use.

- T**he water will safely absorb all microwave energy, if the oven is accidentally started.
- Improper use could result in damage to your oven.
- 7 Do not cook food wrapped in paper towels, unless your cook book contains instructions for the food you are cooking. And do not use newspaper in place of paper towels for cooking.**
- Improper use can cause an explosion or a fire.
- 8 Do not use wooden containers and ceramic containers that have metallic (e.g. gold or silver) inlays. Always remove metal twist ties. Only use utensils that are suitable for use in microwave ovens. Metallic containers for food and beverages must not be used during microwave cooking.**
- They may heat-up and char. Metal objects in particular may arc in the oven, which can cause serious damage.
- 9 Do not use recycled paper products.**
- They may contain impurities which may cause sparks and/or fires when used in cooking.
- 10 Do not rinse trays and racks by placing them in water just after cooking. This may cause breakage or damage.**
- Improper use could result in damage to your oven.
- 11 Be certain to place the oven so the front of the door is 8 cm or more behind the edge of the surface on which it is placed, to avoid accidental tipping of the appliance.**
- Improper use could result in bodily injury and oven damage.
- 12 Before cooking, pierce the skin of potatoes, apples or any such fruit or vegetables.**
- Not doing so could cause them to burst or rupture.
- 13 Do not cook eggs in their shell. Eggs in their shell and whole hard-boiled eggs should not be heated in microwave ovens since they may explode, even after microwave heating has ended.**
- Pressure will build up inside the egg which will burst.
- 14 Do not attempt deep fat frying in your oven.**
- This could result in a sudden boil over of the hot liquid and may even cause a fire.
- 15 If smoke is observed (or emitted), switch off or unplug the appliance and keep the door closed in order to stifle any flame.**
- Not doing so could cause serious damage such as a fire or electric shock.
- 16 When heating food in plastic or paper containers, keep an eye on the oven due to the possibility of ignition .**
- Your food may leak from the container due to the possibility of container deterioration, which also can cause a fire.
- 17 The temperature of accessible surfaces may be high when the appliance is operating. Do not touch the oven door, outer cabinet, rear cabinet, oven cavity, accessories and dishes during grill mode, convection mode (for ovens fitted with these functions) and auto cook operations, before clearing make sure they are not hot.**
- As they will become hot, there is the danger of a burn unless wearing thick culinary gloves.
- 18 The oven should be cleaned regularly and any food deposits should be removed.**
- Failure to maintain the oven in a clean condition could lead to deterioration of the surface that could adversely affect the life of the appliance and possibly result in a hazardous situation.
- 19 Only use the temperature probe recommended for this oven.**
- You can not ascertain that the temperature is accurate with an unsuitable temperature probe.
  - This model doesn't provide a temperature probe.

**20 This appliance is intended to be used in household and similar applications such as:**

- Staff kitchen areas in shops, offices and other working environments;
- Farm houses;
- By clients in hotels, motels and other residential environments;
- Bed and breakfast type environments.

**This product is intended for domestic household applications only and not for commercial use. It must not be used in mobile applications.**

**21 This appliance can be used by children aged from 8 years and above and persons with reduced physical, sensory or mental capabilities or lack of experience and knowledge if they have been given supervision or instruction concerning use of the appliance in a safe way and understand the hazards involved. Children shall not play with the appliance. Cleaning and user maintenance shall not be made by children unless they are aged from 8 years and above and supervised.**

**22 The microwave oven is intended for heating food and beverages. Drying of food or clothing and heating of warming pads, slippers, sponges, damp cloth and similar may lead to risk of injury, ignition or fire.**

**23 The appliance is not intended to be operated by means of an external timer or separate remote-control system.**

**24 Follow exact directions given by each manufacturer for their popcorn product. Do not leave the oven unattended while the corn is being popped. If corn fails to pop after the suggested times, discontinue cooking. Never use a brown paper bag for popping corn. Never attempt to pop leftover kernels.**

- Overcooking could result in the corn catching a fire.

**25 This appliance must be earthed.**

**Only connect the supply lead plug to an earthed power outlet socket that has the same rating and specification requirement of the oven. If you are unsure about your outlet socket earth connection, it should be checked by an electrical contractor. Never cut off the earth pin of the power plug. ⚡**

**If the supply cord is damaged, it must be replaced by the manufacturer, its service agent or similarly qualified persons in order to avoid a hazard.**

- Improper use may cause serious electric damage or electric shock.

**26 Only use utensils that are suitable for use in microwave ovens.**

**27 This oven should not be used for commercial catering purposes.**

- Improper use could result in damage to your oven.

**28 The microwave oven must not be placed in a cabinet.**

- The microwave oven is intended to be used freestanding.

**29 The power connection may be achieved by having the plug accessible in the event of any occurrence, or by incorporating a switch in the fixed wiring in accordance with the wiring rules.**

- Using improper plug or switch can cause an electric shock or a fire.

**30 The door or the outer surface may get hot when the appliance is operating.**

**31 Keep the appliance and its cord out of reach of children less than 8 years.**

**32 The contents of feeding bottles and baby food jars shall be stirred or shaken and the temperature checked before consumption, in order to avoid burns.**

- 33 **K**eeP the inside and outside of the oven clean. **F**or details of how to clean your oven pls refer to the above content " **T**o **C**lean **Y**our **O**ven ".
- 34 **A**lways install the oven according to the installation requirements that are outlined in this manual.
- 35 **D**o not use any steam cleaners to clean the oven.
- 36  **C**autiOn, hot surface  
**W**hen the symbol is used, It means that the surfaces are liable to get hot during use.
- 37 **D**o not place an object (a book, a box, ect.) on the product. **T**he product may overheat or catch fire or the object may fall, causing injury to persons.
- 38 **M**etallic containers for food and beverages are not allowed during microwave cooking.  
**T**his requirement is not applicable if the manufacturer specifies size and shape of metallic containers suitable for microwave cooking.

# BEFORE USE

## Unpacking & Installing

By following the basic steps on these two pages you will be able to quickly check that your oven is operating correctly. Please pay particular attention to the guidelines on where to install your oven. When unpacking your oven make sure you remove all accessories and packing materials. Check to make sure that your oven has not been damaged during shipping.

1 Unpack your oven and place it on a flat level surface.

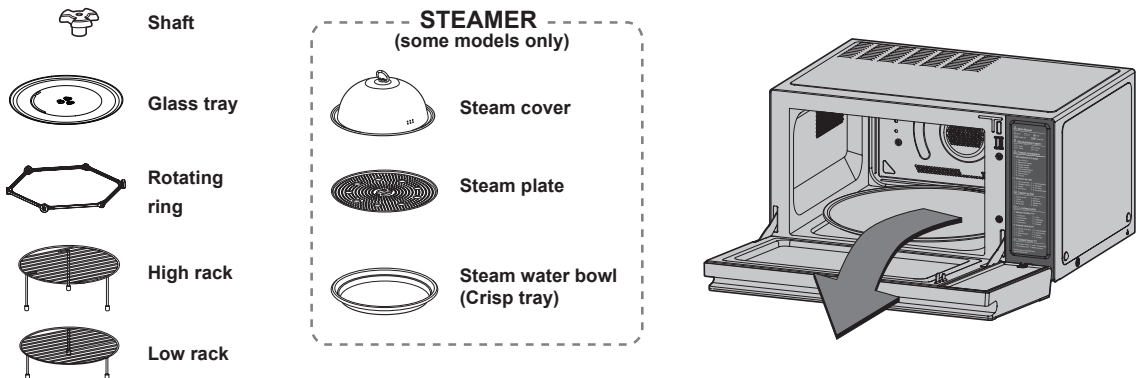

### Method to use Accessories As per Mode

	Microwave	Grill	Convection	Grill combi	Conv combi
Glass tray	○	○	○	○	○
High rack	-	○	○	○	○
Low rack	-	○	○	○	○
Crisp tray	○	○	○	○	○
Steamer	○	-	-	-	-

Caution: Use accessories in accordance with cooking guides!

○ Acceptable  
- Not Acceptable

### NOTE

- Be certain to use proper accessories on each operation mode .
- Improper use could result in damage to your oven and accessories, or could result in a fire.

2 Place the oven on a level location of your choice with more than 85cm height but make sure there is at least 20 cm of space on the top and 20 cm at the rear & left & right for proper ventilation. The front of the oven should be at least 8 cm from the front edge of the surface to prevent tipping.

An exhaust outlet is located on the bottom and side of the oven. Blocking the outlet can damage the oven. Do not use the microwave oven in an enclosed space or cupboard, The air flow for cooling the product could be compromised. It may result in lower performance and reduced service life and possible malfunction due to overheating.

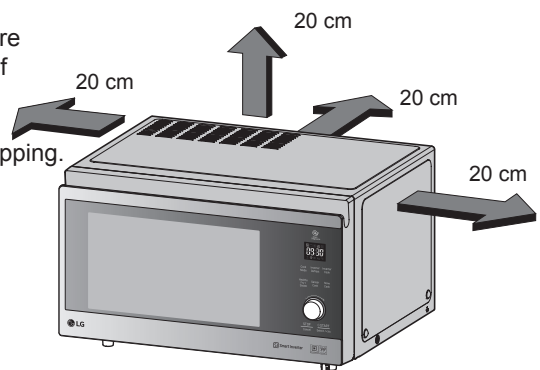

### NOTE

- THIS OVEN SHOULD NOT BE USED FOR COMMERCIAL CATERING PURPOSES. DO NOT USE THIS OVEN IN A BUILT IN APPLICATION.



- 3 Plug your oven into a standard household socket. Make sure your oven is the only appliance connected to the socket.

**If your oven does not operate properly, unplug it from the electrical socket and then plug it back in.**

- 4 Open your oven door by pulling the door handle. Place the rotating ring inside the oven and place the glass tray on top.



- 5 Fill a **microwave safe container** with 300 ml (1/2 pint) of water. Place on the glass tray and close the oven door. If you have any doubts about what type of container to use please refer to Microwave-safe utensils.

- 6 Press the **STOP/CANCEL** button, and press the **START** button one time to start 30 seconds of cooking time.



- 7 The **DISPLAY** will count down from 30 seconds. When it reaches 0 it will chime briefly. Open the oven door and test the temperature of the water. If your oven is operating the water should be warm.

**Be careful when removing the container as it may be hot.**

**YOUR OVEN IS NOW INSTALLED**



- 8 The contents of feeding bottles and baby food jars must be stirred or shaken and the temperature checked before consumption in order to avoid burns.

- 9 Button recognition may be hampered in the following circumstances:

- Only the outside area of the button is pressed.
- The button is pushed using a nail or the tip of the finger.

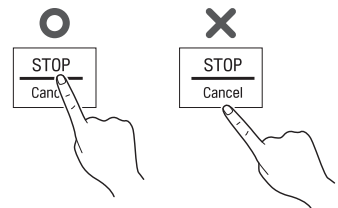

### ! NOTE

Do not use rubber gloves or disposable gloves.

When wiping the touch control panel with a wet towel, remove moisture from the touch control panel when finished.

- 10 The setting of the cooking time should be shorter than common microwave ovens (700 W, 800 W) due to the relatively high output power of the product. Excessive heating of food product may cause moisture on the door. This is not a malfunction.
- 11 All of the recipes in this book give a range of cooking times. In general, you will find that the food remains under-cooked at the lower end of the time range, and you may sometimes want to cook your food beyond the maximum time given, according to personal preference. The governing philosophy of this book is that it is best for a recipe to be conservative in giving cooking times because overcooked food is undesirable.

# CONTROL PANEL

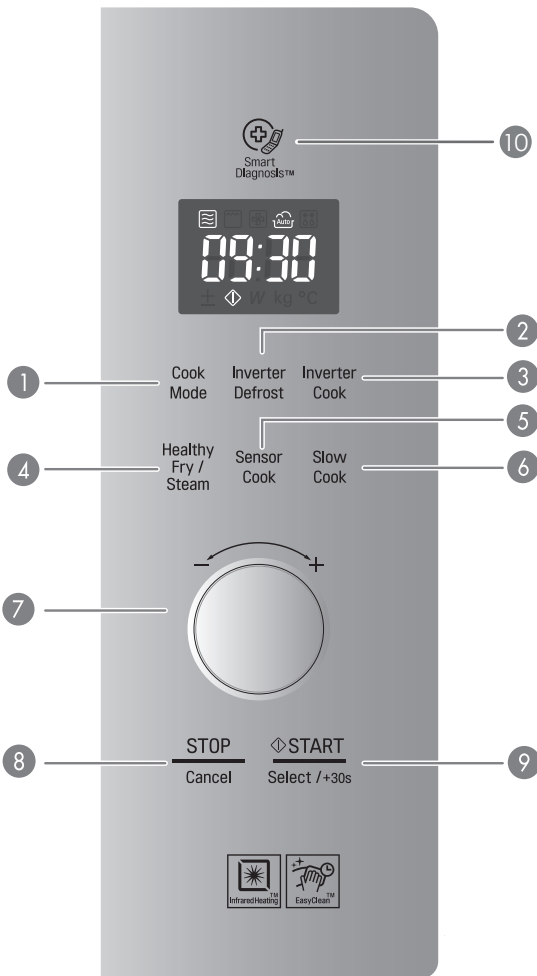

Part	
1	<p><b>COOK MODE</b></p> <p>See page 12 "Microwave"                      See page 13 "Grill"                      See page 13 "Grill Combi(Microwave + Grill)"                      See page 14 "Convection"                      See page 15 "Conv Combi(Microwave + Conv)"</p>
2	<p><b>INVERTER DEFROST</b></p> <p>See page 29 "Inverter Defrost"</p>
3	<p><b>INVERTER COOK</b></p> <p>See page 16 "Inverter cook"</p>
4	<p><b>HEALTHY FRY / STEAM</b></p> <p>See page 22 "Healthy Fry / Steam"</p>
5	<p><b>SENSOR COOK</b></p> <p>See page 25 "Sensor Cook "</p>
6	<p><b>SLOW COOK</b></p> <p>See page 27 "Slow Cook"</p>
7	<p><b>DIAL (MORE / LESS)</b></p> <ul style="list-style-type: none"> <li>• Set cooking time, temperature and power level.</li> <li>• While cooking with auto and manual function, you can increase or decrease the cooking time at any point by turning the dial (except defrost mode).</li> </ul>
8	<p><b>STOP / CANCEL</b></p> <ul style="list-style-type: none"> <li>• Clears all functions and set entries except time of day.</li> </ul>
9	<p><b>START</b></p> <ul style="list-style-type: none"> <li>• Press this button to start cooking or resume cooking if the door was opened or the STOP button was pressed once.</li> <li>• The quick start feature allows you to set 30 second intervals of HIGH power cooking with each press of the START button.</li> </ul>
10	<p><b>SMART DIAGNOSIS</b></p> <p>Hold the mouthpiece of a phone up to this icon when directed to by service centre personnel, to help diagnose problems with the microwave oven when calling for service.</p>

# DISPLAY ICON MEANINGS

Icon			
	Shows when the Microwave function is in operation		Shows when the Auto Cook function is in operation
	Shows when the Grill function is in operation		Shows when the Inverter defrost Microwave function is in operation
	Shows when the Convection function is in operation		Shows when More or Less can be set or adjusted
	Shows when the Convection Temperature needs to be set		Is shown flashing on the display, when the cooking can be Started
	Shows when the Grill Combi function is in operation	<b>P-10~HI</b>	Shows when the Output Power can be set.
	Shows when the Convection Combi function is in operation	<b>kg</b>	Shows when the weight can be set

## SETTING THE CLOCK

When your oven is plugged in for the first time or when power resumes after a power interruption, the numbers in the display reset to '12H'.

### Example: To set 11:11 .

1. Press **START** to confirm the 12Hr clock display. (If you wish to have a 24Hr clock display, simply turn the DIAL to select '24H' before following next steps)
2. Turn the **DIAL** until display shows '11:'.
3. Press **START**.
4. Turn the **DIAL** to change the minutes until the display shows '11:11'.
5. Press **START**.

Clock is now set. If you don't want to use clock mode, press STOP/CLEAR button, after plugging in your oven.

## QUICK START

The QUICK START feature allows you to set 30 seconds intervals of HIGH power cooking with each touch of the START button.

### Example: Set 2 minutes of cooking on high power

1. Press **STOP/CANCEL**.
2. To select 2 minutes on high power.

Press the **START** button four times The oven will start before you have finished the fourth press. During QUICK START cooking, you can extend the cooking time up to 99 minutes 59 seconds by repeatedly pressing the **START** button.

## MORE/LESS

By turning the dial, manual cook settings can be adjusted to cook food for a longer or shorter time. Turning the dial will increase 10 seconds or decrease 10 seconds to the cooking time each time. The max cooking time possible in the manual cook mode will be 99 minutes 59 seconds

### Example: To adjust the Inverter Cook (ex. 0.3kg chicken nuggets) cooking time for a longer time, or for a shorter time.

1. Press **STOP/CANCEL**.
2. Press **INVERTER COOK** until display shows '1'.
3. Turn the **DIAL** until display shows '1-3'.
4. Press **START**. Turn the **DIAL** until display shows '0.3 kg'.
5. Press **START**.
6. Turn the Dial to lengthen or shorten the cooking time by 10 second increments.

### NOTE

- If you suspect that your food maybe over or undercooked when using the preset COOK program, you can increase or decrease the cooking time by turning the **DIAL**.
- You can lengthen or shorten the cooking time (except defrost mode) at any point by turning the **DIAL**.

## ENERGY SAVING

Energy saving means saving energy by automatically turning off the display. This feature only operates when the Microwave Oven is in standby and the display will automatically go out.

### NOTE

- If the clock has been set, the Energy saving mode will not operate. The Energy saving mode will only operate if the clock was not set.

# HOW TO USE

## MANUAL COOKING (timed cooking)

This function allows you to cook food for a desired time. There are 10 power levels available. The example below shows how to set a 90 % power level for 5 minutes and 30 seconds

**Example: To cook food on 90 % Power for 5 minutes 30 seconds**

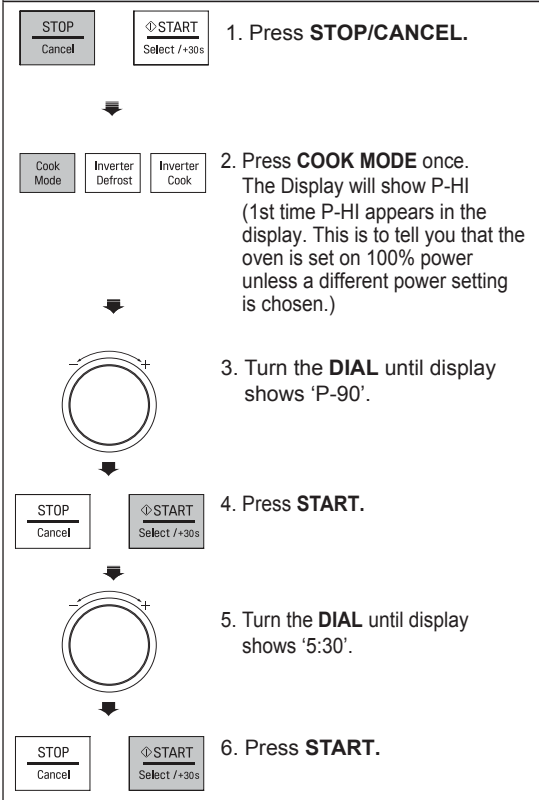

When cooking is complete, a chime will sound. The word End shows in the display window. 'End' remains in the display and the chime will sound every minute for 5 minutes, or until the door is opened or any button is pressed.

### NOTE:

If you do not select a power level, the oven will operate at power HIGH. To set HI-POWER cooking, skip step 3 above.

## MICROWAVE POWER LEVELS

Your microwave oven is equipped with 10 power levels to give you maximum flexibility and control over cooking. The adjacent table will give you some idea of which foods are prepared at each of the various power levels.

- The adjacent chart shows the power level settings for your oven.

### MICROWAVE POWER LEVEL CHART

Power Level	Use
P-HI (100%) 1100 W	* Boiling water. * Browning ground beef. * Making candy. * Cooking poultry pieces, fish, & vegetables. * Cooking tender cuts of meat.
P-90 990 W	* Reheating rice, pasta, & vegetables.
P-80 880 W	* Reheating prepared foods quickly. * Reheating sandwiches.
P-70 770 W	* Cooking egg, milk and cheese dishes. * Cooking cakes and breads. * Melting chocolate.
P-60 660 W	* Cooking veal. * Cooking whole fish. * Cooking puddings and custard.
P-50 550 W	* Cooking ham, whole poultry and lamb. * Cooking rib roast and sirloin tip.
P-40 440 W	* Thawing meat, poultry and seafood.
P-30 330 W	* Cooking less tender cuts of meat. * Cooking pork chops and roast.
P-20 220 W	* Taking chill out of fruit. * Softening butter.
P-10 110 W	* Keeping casseroles and main dishes warm. * Softening butter and cream cheese.

### NOTE

- Do not use the following accessories in Microwave mode.



HIGH RACK



LOW RACK

## GRILL COOKING

This feature will allow you to brown and crisp food quickly.

Always use gloves when removing food and accessories after cooking as the oven & accessories will be very hot.

**Example: Use Grill to cook food for 5 minutes 30 seconds**

1. Press **STOP/CANCEL**.
2. Press **COOK MODE** until display shows 'GRIL'.
3. Press **START**.
4. Turn the **DIAL** until display shows '5:30'.
5. Press **START**.

### CAUTION

- Always use oven gloves when removing the food and accessories after cooking as the oven & accessories will be very hot.

### NOTE

- This feature will allow you to brown and crisp food quickly.
- For the best result use the High Rack
- Do not use any plastic container or trays, or, the Steamer accessory for any Convection or Grill functions.



HIGH RACK



STEAMER

## GRILL COMBI. COOKING

Your oven has a combination cooking feature which allows you to cook food using the built in Grill heater and microwave.

**Example: Programme your oven with micro power 330 W and grill for a cooking time of 25 minutes**

1. Press **STOP/CANCEL**.
2. Press **COOK MODE** until display shows 'GC-1'.
3. Turn the **DIAL** until display shows 'GC-2'.
4. Press **START**.
5. Turn the **DIAL** until display shows '25:00'.
6. Press **START**.  
When cooking you can turn the DIAL to increase or decrease the cooking time.  
Be careful when removing your food as the cooking vessel will be hot!

### NOTE

- Your oven has a combination cooking feature which allows you to cook food using the built in Grill Heater and Microwave.

This generally means it takes less time to cook your food.

- You can select three different levels of microwave power in the Grill Combi. function (GC-1: 220 W, GC-2: 330 W, GC-3: 440 W). in grill combi mode.
- For the best result use the High Rack.
- Do not use any plastic container or trays, or, the Steamer accessory for any Convection or Grill functions.



HIGH RACK



STEAMER

## CONVECTION PREHEAT

Always use gloves when removing food and accessories after cooking as the oven & accessories will be very hot.

**Example: To preheat the oven to a temperature of 200 °C.**

1. Press **STOP/CANCEL**.
2. Press **COOK MODE** until display shows '180 °C'.
3. Turn the **DIAL** until display shows '200 °C'.
4. Press **START** to lock in the temperature and to set a preheating time if desired. If a time is entered, the set temperature may not be achieved.
5. Press **START**. Preheating will start and show 60° in the display. The temperature on the display will then rise to reflect the actual cavity temperature.

### NOTE

- The convection oven has a temperature range of 40~200 °C.
- The oven has a ferment function at the oven temperature of 40 °C. You may need to wait until the oven is cool because you cannot use a ferment function if the oven temperature is over 40 °C.
- Your oven will take a few minutes to reach the selected temperature.
- Once it has reached correct temperature, your oven will BEEP to let you know that it has reached the correct temperature.
- Then place your food in your oven and to start cooking.

## CONVECTION COOKING

The metal tray or metal rack must be used during convection cooking.

**Example: To cook some food at a temperature of 200 °C for 50 minutes.**

1. Press **STOP/CANCEL**.
2. Press **COOK MODE** until display shows '180 °C'.
3. Turn the **DIAL** until display shows '200 °C'.
4. Press **START** for temperature confirmation.
5. Turn the **DIAL** until display shows '50:00'.
6. Press **START**. When cooking you can turn the **DIAL** to increase or decrease the cooking time.

### CAUTION

- Always use oven gloves when removing the food and accessories after cooking as the oven & accessories will be very hot.

### NOTE

- If you do not set a temperature your oven will automatically select 180 °C, the cooking temperature can be changed by turning the **DIAL**.
- For the best result please use the following accessories.



## CONVECTION COMBI. COOKING

In the following example, it shows you how to program your oven at a microwave power of 330 W and at a convection temperature of 200 °C for a cooking time of 25 minutes.

**Example: To cook food at a convection combi. mode for 25 minutes.**

1. Press **STOP/CANCEL**.
2. Press **COOK MODE** until display shows 'CC-1'.
3. Turn the **DIAL** until display shows 'CC-2'.
4. Press **START**. Turn the **DIAL** until display shows '200 °C'.
5. Press **START**. Turn the **DIAL** until display shows '25:00'.
6. Press **START**. When cooking you can turn the **DIAL** to increase or decrease the cooking time. Be careful when removing your food as the cooking vessel will be hot!

### CAUTION

- Always use oven gloves when removing the food and accessories after cooking as the oven & accessories will be very hot.

### NOTE

- You can select three different levels of microwave power in Convection Combi mode. (CC-1: 220 W, CC-2: 330 W, CC-3: 440 W).
- For the best result use the Low Rack.
- Do not use the STEAMER for this function.



LOW RACK



STEAMER

## CHILD LOCK

This is a unique safety feature that prevents unwanted oven operations. Once the CHILD LOCK is set, no cooking can take place.

### Example: To set the CHILD LOCK

1. Press **STOP/CANCEL**.
2. Press and hold **STOP/CANCEL** until 'Loc' appears in the display and a chime is heard. If the time of day was already set, the time of day will appear on the display window after 1 second.

If the CHILD LOCK is enabled and you touch a key pad, the word Loc shows in the display. You can cancel the CHILD LOCK according to below procedure.

### Example: To cancel the CHILD LOCK

Press and hold **STOP/CANCEL** until 'Loc' disappears in the display.

After the CHILD LOCK is turned off, the oven will operate normally.

## INVERTER COOK

Your oven's menu has been preprogrammed to automatically cook food. Select a menu from the below, select the weight and then allow the microwave oven to do the rest. To select the different menu Codes, turn the dial (as in step 3) until the respective menu code appears.

**Example: To cook 0.3 kg Cheese Sticks**

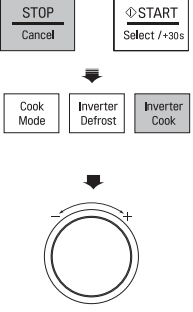

1. Press **STOP/CANCEL**.
2. Press **INVERTER COOK** until display shows '1'.
3. Turn the **DIAL** until display shows '1-2'.

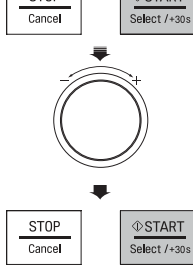

4. Press **START**.
5. Turn the **DIAL** until display shows '0.3 kg'.
6. Press **START**.

## DEFROST & COOK MENU INSTRUCTIONS

Adjust cook time according to the size, thickness, and your preference of doneness.

Code	Menu	Weight Limit	Initial Temperature	Instructions	Utensil
1-1	<b>Baguette/ Croissant</b>	0.1 - 0.3 kg (50 - 100 g/ piece)	Frozen	1. Place frozen bread on the Low rack. Choose the menu and weight, press start.	Low rack
1-2	<b>Cheese Sticks</b>	0.2 - 0.4 kg	Frozen	1. Brush cheese sticks with oil. 2. Place food on the Crisp tray on the High rack. Choose the menu and weight, press start. 3. When BEEP, turn food over and press start to continue cooking.	Crisp tray on the High rack
1-3	<b>Chicken Nuggets</b>	0.2 - 0.3 kg	Frozen	1. Place chicken nuggets on the Crisp tray on the High rack. Choose the menu and weight, press start. 2. When BEEP, turn food over and press start to continue cooking.	Crisp tray on the High rack
1-4	<b>Frozen Lasagna</b>	0.3 kg	Frozen	1. Remove tray from outer carton and remove protective film. 2. Place food on the Low rack. Choose the menu, press start. 3. After cooking, stand covered for 2 minutes.	Low rack
1-5	<b>Frozen Pizza (Thick)</b>	0.5 kg	Frozen	1. Remove thick-crust pizza from all packaging. 2. Place food on the Crisp tray on the Low rack. Choose the menu, press start.	Crisp tray on the Low rack
1-6	<b>Frozen Pizza (Thin)</b>	0.2 - 0.4 kg	Frozen	1. Remove thin-crust pizza from all packaging. 2. Place food on the Crisp tray on the Low rack. Choose the menu and weight, press start.	Crisp tray on the Low rack
1-7	<b>Salmon Fillets</b>	0.2 - 0.6 kg	Frozen	1. Choose salmon fillets of 200 g and 2,5 cm thick each. Brush salmon fillets with oil and season as desired. 2. Place food on the Crisp tray on the High rack. Choose the menu and weight, press start. 3. When BEEP, turn food over and press start to continue cooking.	Crisp tray on the High rack
1-8	<b>Shrimps</b>	0.2 - 0.4 kg	Frozen	1. Brush shrimps with oil and season as desired. 2. Place food on the Crisp tray on the High rack. Choose the menu and weight, press start. 3. When BEEP, turn food over and press start to continue cooking.	Crisp tray on the High rack



## POPULAR MENU INSTRUCTIONS

Adjust cook time according to the size, thickness, and your preference of doneness.

Code	Menu	Weight Limit	Initial Temperature	Instructions	Utensil
2-1	Apple Tart	1	Room	<div style="border: 1px solid black; padding: 5px; margin-bottom: 10px;"> <b>Ingredients</b>            1 short crust pastry dough            5 apples            20 g sugar            2 tablespoons liquid honey         </div> <ol style="list-style-type: none"> <li>On a lightly floured surface, roll out pastry into a round shape and put in the crisp tray. Trim edges, leaving little overhang. Prick with a fork and set aside.</li> <li>Chop 2 1/2 apples and place in a frying pan with sugar. Simmer until apple is soft. Cut remaining apples into 5 mm slices.</li> <li>Spread cooked apples onto dough and arrange sliced apples in spiraling rosettes over the entire surface. Finally spread honey on the top of apples.</li> <li>Place the Crisp tray on the Low rack. Choose the menu, press start.</li> <li>After cooking, remove from the oven and let them cool.</li> </ol>	Crisp tray on the Low rack
2-2	Lamb Chops	0.2 - 0.6 kg	Refrigerated	<ol style="list-style-type: none"> <li>Choose lamb chops of 100 - 150 g weight and 1.5 - 2.0 cm thickness each. Season with salt and pepper or as desired.</li> <li>Place food on the High rack on a drip dish. Choose the menu and weight, press start.</li> <li>When BEEP, turn food over and press start to continue cooking.</li> </ol>	High rack on a drip dish
2-3	Lasagne	1	Room	<div style="border: 1px solid black; padding: 5px; margin-bottom: 10px;"> <b>Ingredients</b>            9 lasagna sheets            500 g spaghetti sauce            600 g cheese sauce            300 g grated mozzarella cheese            30 g grated parmesan cheese         </div> <div style="border: 1px solid black; padding: 5px; margin-bottom: 10px;"> <b>For Cheese sauce :</b>            60 g butter            50 g plain flour            Pinch ground nutmeg            500 ml milk            20 g grated parmesan cheese         </div> <ol style="list-style-type: none"> <li>Melt butter in small saucepan. Add flour and nutmeg, stirring until smooth.</li> <li>Gradually add milk and stir until it boils and thickens.</li> <li>Reduce heat and add parmesan cheese. Stir until cheese melts well.</li> </ol> <ol style="list-style-type: none"> <li>Cook lasagna sheets according to package directions and drain.</li> <li>Spread about 125 g spaghetti sauce in a 26 x17 cm baking dish.</li> <li>Layer 3 lasagna sheets, 300 g cheese sauce, 125 g spaghetti sauce, 100 g mozzarella cheese. Repeat layering.</li> <li>Finally layer remaining lasagna sheets, spread 125 g spaghetti sauce, sprinkle with 100 g mozzarella cheese and 30 g parmesan cheese.</li> <li>Place baking dish on the Low rack. Choose the menu, press start.</li> </ol>	26 x 17 cm baking dish on the Low rack

Code	Menu	Weight Limit	Initial Temperature	Instructions	Utensil
2-4	Meat Pie	1	Room	<p><b>Ingredients</b> 180-200 g meat mixture 2 puff pastry sheets, thawed (600~650 g/sheet) 1 egg, lightly beaten</p> <p><b>For Meat mixture :</b> 1 onion, chopped 500 g steak, finely chopped 2 tablespoons plain flour 250 ml bouillon 1/2 teaspoon thyme Pinch ground nutmeg Salt and pepper to taste Saute chopped onion over a low heat in a saucepan until soften. Add chopped steak and stir until browned. Sprinkle flour over steak and continue cooking for further 2 minutes. Gradually add bouillon and stir constantly until it boils and thickens. Add all remaining ingredients. Cover and simmer for 30 minutes.</p> <ol style="list-style-type: none"> <li>1. On a lightly floured surface, roll out 1 puff pastry sheet into round shape and put in the crisp tray. Trim edges, leaving a little overhang and prick with a fork. Fill with the cooled meat mixture and brush around edges with beaten egg to top will stick to it.</li> <li>2. Roll out the remaining pastry sheet and place on top of pie to form a lid and trim edges. Press edges together with a fork to seal. Cut a vent in top of pie to allow steam to escape. Brush top with remaining beaten egg.</li> <li>3. Place crisp tray on the Low rack. Choose the menu, press start.</li> </ol>	Crisp tray on the Low rack
2-5	Pork Chops	0.2 - 0.6 kg	Refrigerated	<ol style="list-style-type: none"> <li>1. Choose Pork chops of 200 g weight and 2.5 cm thickness each. Season with salt and pepper or as desired.</li> <li>2. Place food on the High rack on a drip dish. Choose the menu and weight, press start.</li> <li>3. When BEEP, turn food over and press start to continue cooking.</li> </ol>	High rack on a drip dish
2-6	Potato Gratin	1.5 kg	Room	<p><b>Ingredients</b> 1 kg potatoes 1 clove garlic 20 g butter 300 g cream 100 g grated cheese Nutmeg, salt and pepper to taste</p> <ol style="list-style-type: none"> <li>1. Peel and wash potatoes then cut into 5 mm slices. Rub inside of a baking dish with garlic clove and butter.</li> <li>2. Place half of potatoes in the baking dish and season. Fill with remaining potatoes and season as desired. Then pour cream and cheese over the top.</li> <li>3. Place the baking dish on the Low rack. Choose the menu, press start.</li> </ol>	20 x 20 cm baking dish on the Low rack

Code	Menu	Weight Limit	Initial Temperature	Instructions	Utensil																				
2-7	Rice/Pasta	0.1 - 0.3 kg	Room	<b>Ingredients for rice</b> <table border="1"> <tr> <td>Rice</td> <td>100 g</td> <td>200 g</td> <td>300 g</td> </tr> <tr> <td>Butter, melted</td> <td>30 g</td> <td>40 g</td> <td>50 g</td> </tr> <tr> <td>Onion, grated</td> <td>50 g</td> <td>75 g</td> <td>100 g</td> </tr> <tr> <td>Chicken stock or water</td> <td>250 ml</td> <td>500 ml</td> <td>750 ml</td> </tr> <tr> <td>Salt</td> <td colspan="3">To taste</td> </tr> </table> <ol style="list-style-type: none"> <li>Add rice, melted butter and onion in a deep and large microwave-safe bowl(3 L) and mix well. Pour boiling chicken stock or water and add salt. Cover with plastic wrap and vent.</li> <li>Place food in the oven. Choose the menu and weight, press start.</li> <li>After cooking, stir and stand covered for 5 - 10 minutes if needed.</li> </ol>	Rice	100 g	200 g	300 g	Butter, melted	30 g	40 g	50 g	Onion, grated	50 g	75 g	100 g	Chicken stock or water	250 ml	500 ml	750 ml	Salt	To taste			Microwave-safe bowl
				Rice	100 g	200 g	300 g																		
Butter, melted	30 g	40 g	50 g																						
Onion, grated	50 g	75 g	100 g																						
Chicken stock or water	250 ml	500 ml	750 ml																						
Salt	To taste																								
<b>Ingredients for pasta</b> <table border="1"> <tr> <td>Pasta</td> <td>100 g</td> <td>200 g</td> <td>300 g</td> </tr> <tr> <td>Water</td> <td>400 ml</td> <td>800 ml</td> <td>1000 ml</td> </tr> <tr> <td>Salt</td> <td colspan="3">To taste</td> </tr> </table> <ol style="list-style-type: none"> <li>Place pasta and boiling water with salt in a deep and large microwave-safe bowl(3 L). Cover with plastic wrap and vent.</li> <li>Place food in the oven. Choose the menu and weight, press start.</li> <li>After cooking, Rinse pasta with cold water.</li> </ol>	Pasta	100 g	200 g	300 g	Water	400 ml	800 ml	1000 ml	Salt	To taste															
Pasta	100 g	200 g	300 g																						
Water	400 ml	800 ml	1000 ml																						
Salt	To taste																								
2-8	Stuffed Zucchini	1.2 kg	Room	<b>Ingredients</b> <table border="1"> <tr> <td>4 round zucchinis of about 200 g each</td> </tr> <tr> <td>500 g ground beef</td> </tr> <tr> <td>2 tablespoons olive oil</td> </tr> <tr> <td>Salt and pepper to taste</td> </tr> </table> <ol style="list-style-type: none"> <li>Cut tops off zucchini to form hats and seed them, taking care not to pierce flesh or skin. Then sprinkle each zucchini with salt and pepper.</li> <li>Stuff zucchinis with ground beef and replace hats.</li> <li>Place food on the Crisp tray on the Low rack and drizzle with olive oil. Choose the menu, press start.</li> </ol>	4 round zucchinis of about 200 g each	500 g ground beef	2 tablespoons olive oil	Salt and pepper to taste	Crisp tray on the Low rack																
4 round zucchinis of about 200 g each																									
500 g ground beef																									
2 tablespoons olive oil																									
Salt and pepper to taste																									

## ROAST & BAKE MENU INSTRUCTIONS

Adjust cook time according to the size, thickness, and your preference of doneness.

Code	Menu	Weight Limit	Initial Temperature	Instructions	Utensil
3-1	Baked Potatoes	0.2 - 1.0 kg (180 - 220 g/ each)	Room	<ol style="list-style-type: none"> <li>1. Wash potatoes and dry with a paper towel.</li> <li>2. Pierce each potato 8 times with a fork.</li> <li>3. Place food on the Low rack. Choose the menu and weight, press start.</li> <li>4. After cooking, stand covered with an aluminum foil for 5 minutes.</li> </ol>	Low rack
3-2	Cookies	1	Room	<div style="border: 1px solid black; padding: 5px; margin-bottom: 10px;"> <p><b>Ingredients</b>  80 g brown sugar  80 g butter, softened  1 egg, lightly beaten  180 g all - purpose flour, sifted  1/2 teaspoon baking powder  1/2 teaspoon baking soda  100 g mini chocolate chips</p> </div> <ol style="list-style-type: none"> <li>1. Mix brown sugar and softened butter. Gradually add egg and stir until light and fluffy. Add flour, baking powder, baking soda and chocolate chips and mix well.</li> <li>2. Drop dough by tablespoon onto the High rack and Low rack covered with an aluminum foil. Cookies should be spaced 2 cm apart.</li> <li>3. Place the High rack and Low rack in the oven. Choose the menu, press start.</li> <li>4. After cooking, remove from the oven and let them cool.</li> </ol>	High rack + Low rack
3-3	Fresh Pizza	1	Room	<div style="border: 1px solid black; padding: 5px; margin-bottom: 10px;"> <p><b>Ingredients</b>  Dough:  120 g all - purpose or bread flour  1 teaspoon active dry yeast  1/3 teaspoon salt  1 teaspoon sugar  70 ml warm water  1 teaspoon extra-virgin olive oil, plus little for coating  Topping:  3 tablespoons pizza sauce  30 g sausage, sliced  1/2 onion, sliced  2 fresh mushrooms, sliced  1/2 fresh pepper  100 g shredded mozzarella cheese</p> </div> <ol style="list-style-type: none"> <li>1. Combine all Ingredients for Dough in a large mixing bowl.</li> <li>2. Knead with an electric mixer to make smooth and elastic dough.</li> <li>3. Roll dough out and place dough on the Crisp tray. Spread pizza sauce. Top with toppings and cheese.</li> <li>4. Place the Crisp tray on the Low rack. Choose the menu, press start.</li> </ol>	Crisp tray on the Low rack

Code	Menu	Weight Limit	Initial Temperature	Instructions	Utensil
3-4	Roast Beef	0.5 - 1.5 kg	Refrigerated	<ol style="list-style-type: none"> <li>1. Brush beef with melted butter or oil and season as desired.</li> <li>2. Place food on the Low rack on a drip dish. Choose the menu and weight, press start.</li> <li>3. When BEEP, drain juices and turn food over immediately. And then press start to continue cooking.</li> <li>4. After cooking, stand covered with an aluminum foil for 10 minutes.</li> </ol>	Low rack on a drip dish
3-5	Roast Chicken	0.8 - 1.8 kg	Refrigerated	<ol style="list-style-type: none"> <li>1. Brush chicken with melted butter or oil and season as desired.</li> <li>2. Place whole chicken breast-side down on the Low rack on a drip dish. Choose the menu and weight, press start.</li> <li>3. When BEEP, drain juices and turn food over immediately. And then press start to continue cooking.</li> <li>4. After cooking, stand covered with an aluminum foil for 10 minutes.</li> </ol>	Low rack on a drip dish
3-6	Roast Pork	0.5 - 1.5 kg	Refrigerated	<ol style="list-style-type: none"> <li>1. Brush pork with melted butter or oil and season as desired.</li> <li>2. Place food on the Low rack on a drip dish. Choose the menu and weight, press start.</li> <li>3. When BEEP, drain juices and turn food over immediately. And then press start to continue cooking.</li> <li>4. After cooking, stand covered with an aluminum foil for 10 minutes.</li> </ol>	Low rack on a drip dish
3-7	Roast Vegetables	0.2 - 0.3 kg	Room	<div style="border: 1px solid black; padding: 5px; margin-bottom: 5px;"> <p><b>Ingredients</b>  Eggplants, cut into 1-2 cm thickness  Zucchini, cut into 1-2 cm thickness  Onions, cut into wedges  Sweet peppers, cut in half lengthwise and discard seeds  Whole cherry tomatoes  Mushrooms, cut in half</p> </div> <ol style="list-style-type: none"> <li>1. Brush vegetables with melted butter or oil and season as desired.</li> <li>2. Place food on the Crisp tray on High rack. Choose the menu and weight, press start.</li> <li>3. When BEEP, turn food over and press start to continue cooking.</li> </ol>	Crisp tray on the High rack
3-8	Small Cakes	1	Room	<div style="border: 1px solid black; padding: 5px; margin-bottom: 5px;"> <p><b>Ingredients</b>  120 g sugar  120 g butter, softened  2 egg, lightly beaten  150 g all - purpose flour, sifted  1 teaspoon baking powder  10~13 ea paper muffin cups  (50 mm base X 30 mm height)</p> </div> <ol style="list-style-type: none"> <li>1. Mix sugar and softened butter. Gradually add eggs and stir until light and fluffy. Add flour and baking powder and mix well. Evenly fill paper muffin cups with batter. (25~30 g per each)</li> <li>2. Place muffin cups on the Crisp tray on the Low rack. Choose the menu, press start.</li> <li>3. After cooking, remove from the oven and let them cool.</li> </ol>	Paper muffin cups on the Crisp tray on the Low rack

## HEALTHY FRY / STEAM

Your oven's menu has been preprogrammed to automatically cook food. Select a menu from the below, select the weight and then allow the microwave oven to do the rest. To select the different menu Codes, turn the dial (as in step 3) until the respective menu code appears.

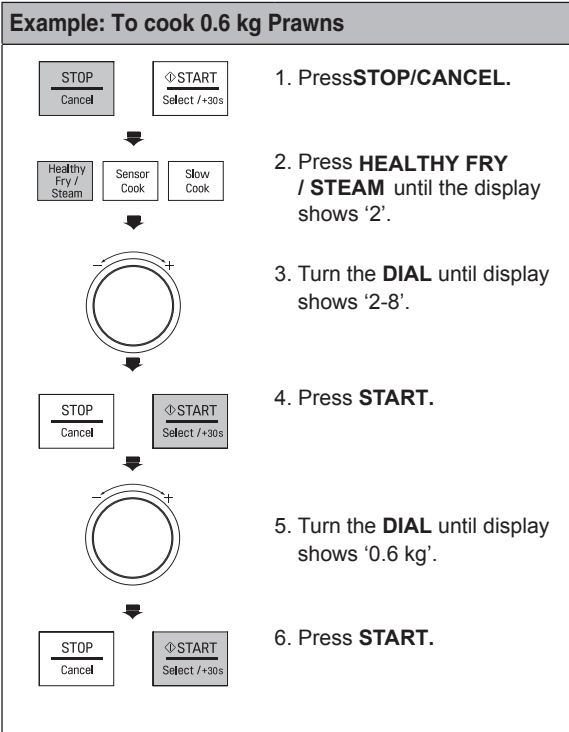

## HEALTHY FRY MENU INSTRUCTIONS

Adjust cook time according to the size, thickness, and your preference of doneness.

Code	Menu	Weight Limit	Initial Temperature	Instructions	Utensil
1-1	<b>Chicken / Schnitzel</b>	0.2 - 0.6 kg	Refrigerated	<p><b>Ingredients</b>                      Chicken breasts of 150 - 200 g each                      1 cup flour                      2 eggs, lightly beaten                      1 cup finely ground breadcrumbs                      Salt and pepper to taste</p> <ol style="list-style-type: none"> <li>1. Season chicken breasts with salt and pepper or as desired, coat in flour and brush with beaten eggs, Coat with finely ground breadcrumbs and brush chicken schnitzel with oil.</li> <li>2. Place food on the Crisp tray on the High rack. Choose the menu and weight, press start.</li> <li>3. When BEEP, turn food over and press start to continue cooking.</li> </ol>	Crisp tray on the High rack
1-2	<b>Chicken Wings</b>	0.2 - 0.6 kg	Refrigerated	<ol style="list-style-type: none"> <li>1. Brush chicken wings with melted butter or oil and season as desired.</li> <li>2. Place food on the Crisp tray on the High rack. Choose the menu and weight, press start.</li> <li>3. When BEEP, turn food over and press start to continue cooking.</li> </ol>	Crisp tray on the High rack

Code	Menu	Weight Limit	Initial Temperature	Instructions	Utensil
1-3	<b>Cutlet</b>	0.2-0.4 kg	Refrigerated	<p><b>Ingredients</b>            500 g lean ground lamb or beef            500 g small potatoes, cooked and mashed            3 eggs, lightly beaten            2 onions, finely chopped            2 tablespoons chopped parsley            1 cup finely ground breadcrumbs            Salt and pepper to taste</p> <p>1. Mix meat, potatoes, eggs, onions and parsley. With meat mixture, make balls about 4-5 cm diameter. Coat with finely ground breadcrumbs and shape balls into ovals about 1 cm thick each. Brush cutlet with oil.            2. Place food on the Crisp tray on the High rack. Choose the menu and weight, press start.            3. When BEEP, turn food over and press start to continue cooking.</p>	Crisp tray on the High rack
1-4	<b>Fish Schnitzel</b>	0.2 - 0.6 kg	Refrigerated	<p><b>Ingredients</b>            Fish fillets of 150 - 200 g each            1 cup flour            2 eggs, lightly beaten            1 cup finely ground breadcrumbs            Salt and pepper to taste</p> <p>1. Season fish fillets with salt and pepper or as desired, coat in flour and brush with beat eggs. Coat with finely ground breadcrumbs and brush crumbled fish with oil.            2. Place food on the Crisp tray on the High rack. Choose the menu and weight, press start.            3. When BEEP, turn food over and press start to continue cooking.</p>	Crisp tray on the High rack
1-5	<b>French Fries</b>	0.1 - 0.3 kg	Frozen	<p>1. Spread frozen potato products out on the Crisp tray on the High rack. For the best results, cook in a single layer. Choose the menu and weight, press start.</p>	Crisp tray on the High rack
1-6	<b>Hamburgers</b>	0.2 - 0.4 kg	Refrigerated	<p>1. Choose hamburgers of 100 g and 1 cm thick each. Brush hamburgers with oil.            2. Place food on the Crisp tray on the High rack. Choose the menu and weight, press start.            3. When BEEP, turn food over and press start to continue cooking.</p>	Crisp tray on the High rack
1-7	<b>Sausages</b>	0.2 - 0.6 kg	Refrigerated	<p>1. Remove all packaging and slit on the surface.            2. Place food on the Crisp tray on the High rack. Choose the menu and weight, press start.            3. When BEEP, turn food over and press start to continue cooking.</p>	Crisp tray on the High rack
1-8	<b>Wedge Potatoes</b>	0.2 - 0.4 kg	Room	<p>1. Wash potatoes and cut into wedges. Brush potatoes with oil.            2. Place food on the Crisp tray on the High rack. Choose the menu and weight, press start.            3. When BEEP, turn food over and press start to continue cooking.</p>	Crisp tray on the High rack

## STEAM CHEF MENU INSTRUCTIONS

Adjust cook time according to the size, thickness, and your preference of doneness.

Code	Menu	Weight Limit	Initial Temperature	Instructions	Utensil
2-1	<b>Broccoli/ Cauliflower</b>	0.2 - 0.6 kg	Room	1. Wash vegetables and cut into similar sized pieces. 2. Pour 300 ml tap water into the steam water bowl. Place the steam plate on the steam water bowl. Place prepared food on the steam plate in a single layer. Cover with steam cover. 3. Place the steam bowl in the oven. Choose the menu and weight, press start. - Cut small florets. (12-15 g/piece)	Steam water bowl Steam plate Steam cover
2-2	<b>Carrot</b>	0.2 - 0.6 kg	Room	Same as above - Under 5 mm thickness	Steam water bowl Steam plate Steam cover
2-3	<b>Chicken Breasts</b>	0.2-0.6 kg	Refrigerated	Same as above - Under 2.5 cm thickness	Steam water bowl Steam plate Steam cover
2-4	<b>Eggs</b>	2 - 9 ea	Refrigerated	Same as above	Steam water bowl Steam plate Steam cover
2-5	<b>Fish Fillets</b>	0.2 - 0.6 kg	Refrigerated	Same as above - Under 2.5 cm thickness	Steam water bowl Steam plate Steam cover
2-6	<b>Green Beans</b>	0.1 - 0.3 kg	Room	Same as above	Steam water bowl Steam plate Steam cover
2-7	<b>Mussels</b>	0.2 - 0.6 kg	Refrigerated	1. Wash mussels and discard any broken shell or dead mussels. 2. Pour 300 ml tap water into the steam water bowl. Place the steam plate on the steam water bowl. Place prepared food on the steam plate in a single layer. Cover with steam cover. 3. Place the steam bowl in the oven. Choose the menu and weight, press start.	Steam water bowl Steam plate Steam cover
2-8	<b>Prawns</b>	0.2 - 0.6 kg	Refrigerated	Same as above - Under 20 cm length	Steam water bowl Steam plate Steam cover

### CAUTION

- Always use oven gloves when removing a STEAMER from the oven after cooking as it will be very hot.
- Do not put a hot STEAMER on a glass table or a place that may melt after cooking.  
Always make sure a pad or tray is used to place it on.
- When you use this STEAMER, pour at least 300 ml of water into the base before using it.  
If the amount of water is less than 300ml, it may cause incomplete cooking, or may cause a fire or damage to the product.
- Be careful when you move the STEAMER that is full of water.
- When you use the STEAMER, the steam cover and Steam water bowl should be set perfectly right. Eggs or chestnuts will explode if the steam cover and steam water bowl are not placed correctly onto the STEAMER tray.
- Never use this STEAMER with any other model or brand of microwave oven as it may cause a fire or irreparable damage to that product.



Steam cover



Steam plate



Steam water bowl  
(Crisp tray)



## SENSOR COOK

Your oven's menu has been preprogrammed to automatically cook food. Select one of the Sensor Cook menus and then dial in the weight of the food before pressing **START** to allow the microwave to cook your selection.

**Example To reheat 0.4 kg Fresh Vegetables**



1. Press **STOP/CANCEL**.



2. Press **SENSOR COOK**.

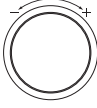

3. Turn the **DIAL** until display shows '2'.



4. Press **START**.

## SENSOR COOK MENU INSTRUCTIONS

Adjust cook time according to the size, thickness, and your preference of doneness

Code	Menu	Weight Limit	Initial Temperature	Instructions	Utensil																																																																											
1	Casserole	1 - 4	Room	<p><b>Tuna &amp; Noodle</b></p> <table border="1"> <thead> <tr> <th>Serving</th> <th>1</th> <th>2</th> <th>3</th> <th>4</th> </tr> </thead> <tbody> <tr> <td>Noodles(Pasta), boiled</td> <td>140 g</td> <td>280 g</td> <td>420 g</td> <td>560 g</td> </tr> <tr> <td>Cream of mushroom soup</td> <td>140 g</td> <td>280 g</td> <td>420 g</td> <td>560 g</td> </tr> <tr> <td>Can or equivalent, Starkist chunk light tuna, in spring water, drained</td> <td>60 g</td> <td>120 g</td> <td>180 g</td> <td>240 g</td> </tr> <tr> <td>Milk</td> <td>125 ml</td> <td>250 ml</td> <td>375 ml</td> <td>500 ml</td> </tr> </tbody> </table> <ol style="list-style-type: none"> <li>Combine cream of mushroom soup, tuna and milk on a microwave- safe bowl. Add boiled noodles and stir thoroughly. Cover with plastic wrap and vent.</li> <li>Place food in the oven. Choose the menu and weight, press <b>START</b>.</li> <li>After cooking, stand covered for 3 minutes.</li> </ol> <p><b>Beef Stroganoff</b></p> <table border="1"> <thead> <tr> <th>Serving</th> <th>1</th> <th>2</th> <th>3</th> <th>4</th> </tr> </thead> <tbody> <tr> <td>Rump steak, cubed</td> <td>250 g</td> <td>500 g</td> <td>750 g</td> <td>1000 g</td> </tr> <tr> <td>Plain flour</td> <td>2 Tbsp</td> <td>1/4 cup</td> <td>1/2 cup</td> <td>1/2 cup</td> </tr> <tr> <td>Small onion, finely chopped</td> <td>1/2</td> <td>1</td> <td>1</td> <td>1</td> </tr> <tr> <td>Tomato puree</td> <td>2 tsp</td> <td>1 Tbsp</td> <td>1 1/2 Tbsp</td> <td>2 Tbsp</td> </tr> <tr> <td>Beef stock</td> <td>125 ml</td> <td>200 ml</td> <td>250 ml</td> <td>375 ml</td> </tr> <tr> <td>Red wine</td> <td>60 ml</td> <td>60 ml</td> <td>60 ml</td> <td>60 ml</td> </tr> <tr> <td>Mushroom, sliced</td> <td>25 g</td> <td>50 g</td> <td>75 g</td> <td>100 g</td> </tr> <tr> <td>Sour cream</td> <td>75 ml</td> <td>150 ml</td> <td>200 ml</td> <td>300 ml</td> </tr> <tr> <td>Salt and pepper to taste</td> <td></td> <td></td> <td></td> <td></td> </tr> </tbody> </table> <ol style="list-style-type: none"> <li>Place steak, left flour and all other ingredients in a microwave-safe bowl. Cover with plastic wrap and vent.</li> <li>Place food in the oven. Choose the menu, press <b>start</b>.</li> <li>After cooking, stand covered for 3 minutes.</li> </ol>	Serving	1	2	3	4	Noodles(Pasta), boiled	140 g	280 g	420 g	560 g	Cream of mushroom soup	140 g	280 g	420 g	560 g	Can or equivalent, Starkist chunk light tuna, in spring water, drained	60 g	120 g	180 g	240 g	Milk	125 ml	250 ml	375 ml	500 ml	Serving	1	2	3	4	Rump steak, cubed	250 g	500 g	750 g	1000 g	Plain flour	2 Tbsp	1/4 cup	1/2 cup	1/2 cup	Small onion, finely chopped	1/2	1	1	1	Tomato puree	2 tsp	1 Tbsp	1 1/2 Tbsp	2 Tbsp	Beef stock	125 ml	200 ml	250 ml	375 ml	Red wine	60 ml	60 ml	60 ml	60 ml	Mushroom, sliced	25 g	50 g	75 g	100 g	Sour cream	75 ml	150 ml	200 ml	300 ml	Salt and pepper to taste					Microwave-safe bowl
Serving	1	2	3	4																																																																												
Noodles(Pasta), boiled	140 g	280 g	420 g	560 g																																																																												
Cream of mushroom soup	140 g	280 g	420 g	560 g																																																																												
Can or equivalent, Starkist chunk light tuna, in spring water, drained	60 g	120 g	180 g	240 g																																																																												
Milk	125 ml	250 ml	375 ml	500 ml																																																																												
Serving	1	2	3	4																																																																												
Rump steak, cubed	250 g	500 g	750 g	1000 g																																																																												
Plain flour	2 Tbsp	1/4 cup	1/2 cup	1/2 cup																																																																												
Small onion, finely chopped	1/2	1	1	1																																																																												
Tomato puree	2 tsp	1 Tbsp	1 1/2 Tbsp	2 Tbsp																																																																												
Beef stock	125 ml	200 ml	250 ml	375 ml																																																																												
Red wine	60 ml	60 ml	60 ml	60 ml																																																																												
Mushroom, sliced	25 g	50 g	75 g	100 g																																																																												
Sour cream	75 ml	150 ml	200 ml	300 ml																																																																												
Salt and pepper to taste																																																																																

Code	Menu	Weight Limit	Initial Temperature	Instructions	Utensil
2	<b>Fresh Vegetables</b>	0.2 - 0.8 kg	Room	<ol style="list-style-type: none"> <li>1. Prepare vegetables(carrots, broccoli, cauliflower, zucchini, beans, peas).</li> <li>2. Cut vegetables into even size pieces. Wash the vegetables and place food in a microwave- safe bowl.</li> <li>3. Add amount of water according to the quantity (0.2 - 0.4 kg: 2 tablespoons, 0.5 - 0.8 kg: 4 tablespoons). Cover with plastic wrap and vent.</li> <li>4. Place food in the oven. Choose the menu and weight, press START.</li> <li>5. After cooking, stir and stand covered for 3 minutes.</li> </ol>	Microwave-safe bowl
3	<b>Frozen Vegetables</b>	0.2 - 0.8 kg	Frozen	<ol style="list-style-type: none"> <li>1. Prepare frozen vegetables(carrots, broccoli, cauliflower, zucchini, beans, peas).</li> <li>2. Place food in a microwave-safe bowl.</li> <li>3. Add amount of water according to the quantity( 0.2 - 0.4 kg: 2 tablespoons, 0.5 - 0.8 kg: 4 tablespoons). Cover with plastic wrap and vent.</li> <li>4. Place food in the oven. Choose the menu and weight, press START.</li> <li>5. After cooking, stir and stand covered for 3 minutes.</li> </ol>	Microwave-safe bowl
4	<b>Jacket Potatoes</b>	0.2 - 1.0 kg (180 - 220 g / each)	Room	<ol style="list-style-type: none"> <li>1. Wash potatoes and dry with a paper towel.</li> <li>2. Pierce each potato 8 times with a fork.</li> <li>3. Place food on a paper towel in the oven. Choose the menu and weight, press START.</li> <li>4. After cooking, stand for 3 minutes.</li> </ol>	Paper towel
5	<b>Risotto</b>	1.2 kg	Room	<div style="border: 1px solid black; padding: 5px; margin-bottom: 10px;"> <p><b>Ingredients</b>  200 g risotto rice  1 1/2 cups water or stock  1/2 cup milk  200 g beef, chopped  2 eggs  1 onion, chopped  50 g green peas  100 g grated cheese  Salt and pepper to taste</p> </div> <ol style="list-style-type: none"> <li>1. Add all ingredients in a deep and large microwave-safe bowl and mix well. Cover with plastic wrap and vent.</li> <li>2. Place the bowl in the oven. Choose the menu, press start.</li> <li>3. After cooking, stir and stand covered for 5 - 10 minutes if needed.</li> </ol>	Microwave-safe bowl
6	<b>Soup / Sauce</b>	0.25 – 1.0 kg (250 g/ 1 serving)	Room	<ol style="list-style-type: none"> <li>1. Place food on a microwave-safe bowl. Cover with plastic wrap and vent.</li> <li>2. Place food in the oven. Choose the menu and weight, press start.</li> <li>3. After cooking, stand covered for 3 minutes.</li> </ol>	Microwave-safe bowl

## SLOW COOK

### Example : How to set 60° for 5Hrs (Food drying)

1. Press **STOP/CANCEL**.

2. Press **SLOW COOK** until display shows '2'.

3. Turn the **DIAL** until display shows '60 °C'.

4. Press **START**. '10:00' will show in the display.

5. Turn the **DIAL** until display shows '5h00'.

6. Press **START**. When cooking you can increase or decrease the cooking time by turning the **DIAL**.

## SLOW COOK MENU INSTRUCTIONS

Function	Range	Step	Default	Instructions	Utensil																			
<b>1. Slow Cook</b>	130 °C (HIGH) / 110 °C (LOW)	-	130 °C (HIGH)	<p>This function maintains a relatively low temperature compared to other cooking methods (such as baking, boiling and frying) for many hours allowing unattended cooking of pot roast, stew and other suitable dishes.</p> <p><b>110 °C (LOW) Setting</b> The low setting gently simmers food for an extended period of time without overcooking or burning. No stirring is required when using this setting.</p> <p><b>130 °C (HIGH) Setting</b> The high setting will cook food in approximately half the time required for the low setting. Some foods may boil when cooked on the high setting, so it may be necessary to add extra liquid.</p> <p>Occasional stirring of stews and casseroles will improve flavour distribution. Searing and browning before slow cooking is not necessary, but this will help to seal in the juices and flavours and keeps the meat tender.</p> <p><b>Slow cook guide</b></p> <table border="1"> <thead> <tr> <th rowspan="2">Traditional cooking time</th> <th colspan="2">Slow cooker cooking time (without searing)</th> <th colspan="2">Slow cooker cooking time (with searing)</th> </tr> <tr> <th>110 °C(Low)</th> <th>130 °C(High)</th> <th>110 °C(Low)</th> <th>130 °C(High)</th> </tr> </thead> <tbody> <tr> <td>35 to 60 minutes</td> <td>6 to 9 hrs</td> <td>3 to 4 hrs</td> <td>4 to 6 hrs</td> <td>2 to 3 hrs</td> </tr> <tr> <td>1 to 3 hours</td> <td>8 to 9 hrs</td> <td>4 to 6 hrs</td> <td>5 to 6 hrs</td> <td>3 to 4 hrs</td> </tr> </tbody> </table>	Traditional cooking time	Slow cooker cooking time (without searing)		Slow cooker cooking time (with searing)		110 °C(Low)	130 °C(High)	110 °C(Low)	130 °C(High)	35 to 60 minutes	6 to 9 hrs	3 to 4 hrs	4 to 6 hrs	2 to 3 hrs	1 to 3 hours	8 to 9 hrs	4 to 6 hrs	5 to 6 hrs	3 to 4 hrs	Heatproof glass dish placed on the turntable
Traditional cooking time	Slow cooker cooking time (without searing)		Slow cooker cooking time (with searing)																					
	110 °C(Low)	130 °C(High)	110 °C(Low)	130 °C(High)																				
35 to 60 minutes	6 to 9 hrs	3 to 4 hrs	4 to 6 hrs	2 to 3 hrs																				
1 to 3 hours	8 to 9 hrs	4 to 6 hrs	5 to 6 hrs	3 to 4 hrs																				

Function	Range	Step	Default	Instructions	Utensil																																								
<b>2. Food Drying</b>	40 °C ~ 90 °C	10 °C	70 °C	With this function, you can dry fruit, veggies, and beef into healthy and nutritional snacks and tasty jerky without chemicals and preservatives. Place baking paper on Crisp tray and spread food into a single layer.	Crisp tray on the Low rack																																								
				<p><b>Food Drying guide</b></p> <table border="1"> <thead> <tr> <th>Food type</th> <th>Preparation</th> <th>Set temp</th> <th>Time</th> <th>Use</th> </tr> </thead> <tbody> <tr> <td>Bananas</td> <td>Slice into 5~6 mm thick</td> <td>70 °C</td> <td>5~8hrs</td> <td>Snacks, baby food, granola, cookies and banana bread</td> </tr> <tr> <td>Figs</td> <td>Remove stems and halve</td> <td>70 °C</td> <td>8~9hrs</td> <td>Fillings, cakes, puddings, breads and cookies</td> </tr> <tr> <td>Kiwi</td> <td>Peel, slice into 8~12 mm thick</td> <td>70 °C</td> <td>5~8 hrs</td> <td>Snacks</td> </tr> <tr> <td>Mangos</td> <td>Remove skin, slice into 6~10 mm thick</td> <td>70 °C</td> <td>6~9 hrs</td> <td>Snacks, cereals, baked goods</td> </tr> <tr> <td>Pineapple</td> <td>Peel, core, slice into 8~12 mm thick</td> <td>70 °C</td> <td>6~9 hrs</td> <td>Snacks, baked goods, baked granola</td> </tr> <tr> <td>Tomatoes</td> <td>Wash and slice 6mm circles</td> <td>70 °C</td> <td>6~9 hrs</td> <td>Soups, stews, paste or sauce</td> </tr> <tr> <td>Mushroom</td> <td>Clean with soft brush or cloth. Don't wash</td> <td>60 °C</td> <td>4~8 hrs</td> <td>Rehydrate for soups, meat dishes, omelettes or frying</td> </tr> <tr> <td>Beef jerky</td> <td>Marinate sliced meats (5~6 mm thick) in store-bought or your own recipe for 6 to 8 hours in the refrigerator</td> <td>80 °C</td> <td>6~9 hrs</td> <td>Snack</td> </tr> </tbody> </table>		Food type	Preparation	Set temp	Time	Use	Bananas	Slice into 5~6 mm thick	70 °C	5~8hrs	Snacks, baby food, granola, cookies and banana bread	Figs	Remove stems and halve	70 °C	8~9hrs	Fillings, cakes, puddings, breads and cookies	Kiwi	Peel, slice into 8~12 mm thick	70 °C	5~8 hrs	Snacks	Mangos	Remove skin, slice into 6~10 mm thick	70 °C	6~9 hrs	Snacks, cereals, baked goods	Pineapple	Peel, core, slice into 8~12 mm thick	70 °C	6~9 hrs	Snacks, baked goods, baked granola	Tomatoes	Wash and slice 6mm circles	70 °C	6~9 hrs	Soups, stews, paste or sauce	Mushroom	Clean with soft brush or cloth. Don't wash	60 °C	4~8 hrs	Rehydrate for soups, meat dishes, omelettes or frying
Food type	Preparation	Set temp	Time	Use																																									
Bananas	Slice into 5~6 mm thick	70 °C	5~8hrs	Snacks, baby food, granola, cookies and banana bread																																									
Figs	Remove stems and halve	70 °C	8~9hrs	Fillings, cakes, puddings, breads and cookies																																									
Kiwi	Peel, slice into 8~12 mm thick	70 °C	5~8 hrs	Snacks																																									
Mangos	Remove skin, slice into 6~10 mm thick	70 °C	6~9 hrs	Snacks, cereals, baked goods																																									
Pineapple	Peel, core, slice into 8~12 mm thick	70 °C	6~9 hrs	Snacks, baked goods, baked granola																																									
Tomatoes	Wash and slice 6mm circles	70 °C	6~9 hrs	Soups, stews, paste or sauce																																									
Mushroom	Clean with soft brush or cloth. Don't wash	60 °C	4~8 hrs	Rehydrate for soups, meat dishes, omelettes or frying																																									
Beef jerky	Marinate sliced meats (5~6 mm thick) in store-bought or your own recipe for 6 to 8 hours in the refrigerator	80 °C	6~9 hrs	Snack																																									
<b>3. Proof</b>	40 °C	-	40 °C	<p><b>How to make yogurt</b></p> <ul style="list-style-type: none"> <li>• Pour a 1000 ml milk into a proper heat-resistant bowl with cover.</li> <li>• Boil it to proper temperature (up to 60~70 °C) and then cool down to about 40 °C</li> <li>• Add 150 ml natural yogurt into a bowl and stir well.</li> <li>• Place covered bowl in the oven.</li> <li>• Choose the menu, and set cook time 5~8 hours.</li> </ul> <p><b>How to raise yeast dough</b></p> <ul style="list-style-type: none"> <li>• Place the dough in a proper heat-resistant bowl and cover with baking wrap or damp cloth.</li> <li>• Place the bowl in the oven.</li> <li>• Choose the menu, and set cook time to about 40 minutes until the dough has doubled in volume.</li> </ul>	Heat-proof glass bowl on the Low rack																																								
				<p><b>4. Keep warm</b></p>		80 °C 70 °C 60 °C	10 °C	70 °C	Heat from the top and bottom elements are used to maintain set temperature. You can use this function to keep food warm until ready to serve.	Heat-proof glass bowl on the Low rack																																			

## INVERTER DEFROST

Four defrost sequences are preset in the oven. The INVERTER DEFROST feature provides you with the best defrosting method for frozen foods. The cooking guide will show you which defrost sequence is recommended for the food you are defrosting.

For added convenience, the INVERTER DEFROST includes an audible beep function that reminds you to check, turn over, separate, or rearrange to get the best defrost results. Four different defrosting levels are provided.

**(MEAT /POULTRY / FISH / BREAD)**

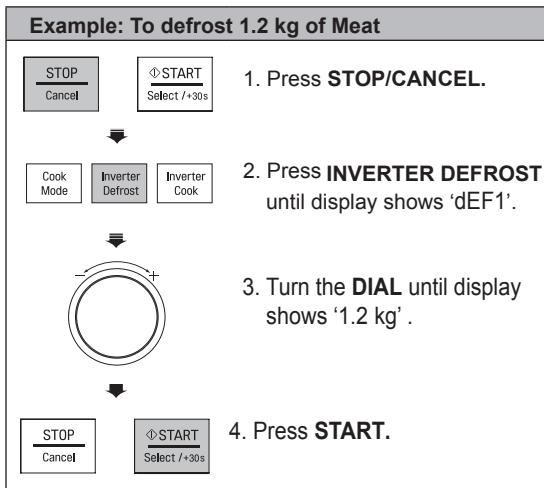

**NOTE:**

When you press the **START** button, the display changes to the defrost time count down. The oven will beep once during the DEFROST cycle.

At the beep, open the door and remove any portions that have thawed and turn the food over. Return frozen portions to the oven and press **START** to resume the defrost cycle.

- Remove fish, shellfish, meat, and poultry from its original wrapping paper or plastic package. Otherwise, the wrap will hold steam and juice close to the foods, which can cause the outer surface of the foods to cook.
- Place foods in a shallow container or in a microwave roasting dish to catch the drippings.
- Food should still be somewhat icy in the center when removed from the oven.
- The length of defrosting time varies according to how solidly the food is frozen.
- The shape of the package affects how quickly food will defrost. Shallow packages will defrost more quickly than a deep block.

## INVERTER DEFROST MENU INSTRUCTIONS

Category	Food to be Defrosted
<b>MEAT (DEF1)</b> 0.1 - 4.0 kg	<b>Beef</b> Ground beef, Round steak, Cubes for stew, Tenderloin steak, Pot roast, Rib roast, Rump roast, Chuck roast, Hamburger patty <b>Lamb</b> Chops, Rolled roast <b>Pork</b> Chops, Hot dogs, Spareribs, Country-style ribs. Rolled roast, Sausage <b>Veal</b> Cutlets (0.5 kg, 20 mm thick) Turn food over at beep. After defrosting, let stand for 5 - 15 minutes.
<b>POULTRY (DEF2)</b> 0.1 - 4.0 kg	<b>Poultry</b> Whole, Cut-up, Breast (boneless) <b>Cornish Hens</b> Whole <b>Turkey</b> Breast Turn food over at beep. After defrosting, let stand for 30 - 60 minutes.
<b>FISH (DEF3)</b> 0.1 - 4.0 kg	<b>Fish</b> Fillets, Whole Steaks <b>Shellfish</b> Crab meat, Lobster tails, Shrimp, Scallops Turn food over at beep. After defrosting, let stand for 5 - 10 minutes.
<b>BREAD (DEF4)</b> 0.1 - 0.5 kg	Sliced bread, Buns, Baguette, etc. Separate slices and place between paper towel or flat plate. Turn food over at beep. After defrosting, let stand for 1-2 minutes.

# MICROWAVE-SAFE UTENSILS

## Never use metal or metal trimmed utensils in using microwave function

Microwaves cannot penetrate metal. They will bounce off any metal object in the oven and cause arcing, an alarming phenomenon that resembles lightning. Most heat resistant non metallic cooking utensils are safe for use in your oven. However, some may contain materials that render them unsuitable as microwave cookware. If you have any doubts about a particular utensil, there's a simple way to find out if it can be used in the microwave.

Place the utensil in question next to a glass bowl filled with water in using microwave function. Microwave at power HIGH for 1 minute. If the water heats up but the utensil remains cool to the touch, the utensil is microwave-safe.

However, if the water does not change temperature but the utensil becomes warm, microwaves are being absorbed by the utensil and it is not safe for use in using microwave function. You probably have many items on hand in your kitchen right now that can be used as cooking equipment in the microwave. Just read through the following checklist.

## Dinner plates

Many kinds of dinnerware are microwave-safe. If in doubt consult the manufacturer's literature or perform the microwave test. Do not heat dinner plates that use any painted on decorative as they will arc if the paint has metallic content.

## Glassware

Glassware that is heat-resistant is microwave-safe. This would include all brands of oven tempered glass cookware. However, do not use delicate glassware, such as tumblers or wine glasses, as these might shatter as the food warms.

## Plastic storage containers

These can be used to hold foods that are to be quickly reheated. However, they should not be used to hold foods that will need considerable time in the oven as hot foods will eventually warp or melt plastic containers.

## Paper

Paper plates and containers are convenient and safe to use in using microwave function, provided that the cooking time is short and foods to be cooked are low in fat and moisture. Paper towels are also very useful for wrapping foods and for lining baking trays in which greasy foods such as bacon are cooked. In general, avoid coloured paper products as the colour may run. Some recycled paper products may contain impurities which could cause arcing or fires when used in the microwave.

## Plastic cooking bags

Provided they are made specially for cooking, cooking bags are microwave safe. However, be sure to make a slit in the bag so that steam can escape. Never use ordinary plastic bags for cooking in using microwave function, as they will melt and rupture.

## Plastic microwave cookware

A variety of shapes and sizes of microwave cookware are available. For the most part, you can probably use items you already have on hand rather than investing in new kitchen equipment.

## Pottery, stoneware and ceramic

Containers made of these materials are usually fine for use in using microwave function, but they should be tested to be sure.



### CAUTION

- Some items with high lead or iron content are not suitable as cooking utensils.
- Utensils should be checked to ensure that they are suitable for use in the microwave.

# FOOD CHARACTERISTICS & MICROWAVE COOKING

## Keeping an eye on things

Always watch your food while it cooks. Your microwave function is equipped with a light that turns on automatically when the oven is in operation so that you can see inside and check the progress of your food. Directions given in recipes to elevate, stir, and the like should be thought of as the minimum steps recommended. If the food seems to be cooking unevenly, simply make the necessary adjustments you think appropriate to correct the problem.

## Factors affecting microwave cooking times

Many factors affect cooking times. The temperature of ingredients used in a recipe makes a big difference in cooking times. For example, a cake made with ice-cold butter, milk, and eggs will take considerably longer to bake than one made with ingredients that are at room temperature. Some of the recipes, particularly those for bread, cake, and custards, recommend that food be removed from the oven when they are slightly undercooked.

This is not a mistake. When allowed to stand, usually covered, these foods will continue to cook outside of the oven as the heat trapped within the outer portions of the food gradually travels inward. If the food is left in the oven until it is cooked all the way through, the outer portions will become overcooked or even burnt. You will become increasingly skillful in estimating both cooking and standing times for various foods.

## Density of food

Light, porous food such as cakes and breads cook more quickly than heavy, dense foods such as roasts and casseroles. You must take care when microwaving porous food so that the outer edges do not become dry and brittle.

## Height of food

The upper portion of tall foods, particularly roasts, will cook more quickly than the lower portion. Therefore, it is wise to turn tall food several during cooking.

## Moisture content of food

Since the heat generated from microwaves causes moisture to evaporate, relatively dry food such as roasts and some vegetables should either be sprinkled with water prior to cooking or covered to retain moisture.

## Bone and fat content of food

Bones conduct heat and fat cooks more quickly than meat. Care must be taken when cooking bony or fatty cuts of meat in order to prevent unevenly or overcooked meat.

## Quantity of food

The number of microwaves in your oven remains constant regardless of how much food is being cooked. Therefore, the more food you place in the oven, the longer the cooking time. Remember to decrease cooking times by at least one third when halving a recipe.

## Shape of food

Microwaves penetrate only about 2 cm into food, the interior portion of thick foods are cooked as the heat generated on the outside travels inward. Only the outer edge of food is cooked by microwave energy; the rest is cooked by conduction. The worst possible shape for a food that is to be microwaved is a thick square.

The corners will burn long before the centre is even warm. Round thin foods and ring shaped foods cook most successfully in the microwave.

## Covering

A cover traps heat and steam which causes food to cook more quickly. Use a lid or microwave cling film with a corner folded back to prevent splitting.

# FOOD CHARACTERISTICS & MICROWAVE COOKING

## Browning

Meats and poultry that are cooked fifteen minutes or longer will brown lightly in their own fat. Foods that are cooked for a shorter period of time may be brushed with a browning sauce such as worcestershire sauce, soy sauce or barbecue sauce to achieve an appetizing colour. Since relatively small amounts of browning sauces are added to food, the original flavour of the recipe is not altered.

## Covering with greaseproof paper

It is a looser cover than a lid or cling film, the food may dry out slightly. But because it makes a looser cover than a lid or clingfilm, it allows the food to dry out slightly.

## Arranging and spacing

Individual foods such as baked potatoes, small cakes and hors d'oeuvres will heat more evenly if placed in the oven an equal distance apart, preferably in a circular pattern. Never stack foods on top of one another.

## Stirring

Stirring is one of the most important of all microwaving techniques. In conventional cooking, food is stirred for the purpose of blending. Microwaved food, however, is stirred in order to spread and redistribute heat. Always stir from the outside towards the centre as the outside of the food heats first.

## Turning over

Large, tall foods such as roasts and whole chickens should be turned so that the top and bottom will cook evenly. It is also a good idea to turn cut up chicken and chops.

## Placing thicker portions facing outwards

Since microwaves are attracted to the outside portion of food, it makes sense to place thicker portions of meat, poultry and fish to the outer edge of the baking dish. This way, thicker portions will receive the most microwave energy and the food will cook evenly.

## Shielding

Strips of aluminium foil (which block microwaves) can be placed over the corners or edges of square and rectangular foods to prevent those portions from overcooking. Never use too much foil and make sure the foil is secured to the dish or it may cause 'arcing' in the oven especially if the foil passes too closely to the walls of the oven during rotation.

## Elevating

Thick or dense foods can be elevated so that microwaves can be absorbed by the underside and centre of the foods.

## Piercing

Foods enclosed in a shell, skin or membrane are likely to burst in the oven unless they are pierced prior to cooking. Such foods include yolks and whites of eggs, clams and oysters and whole vegetables and fruits.

## Testing if cooked

Food cooks so quickly in a oven, it is necessary to test it frequently. Some foods are left in the microwave until completely cooked, but most foods, including meats and poultry, are removed from the oven while still slightly undercooked and allowed to finish cooking during standing time. The internal temperature of foods will rise between 5 ° F (3 ° C) and 15 ° F (8 ° C) during standing time.

## Standing time

Foods are often allowed to stand for 3 to 10 minutes after being removed from the oven. Usually the foods are covered during standing time to retain heat unless they are supposed to be dry in texture (some cakes and biscuits, for example). Standing allows foods to finish cooking and also helps flavour blend and develop.



# TO CLEAN YOUR OVEN

## 1 Keep the inside of the oven clean

Food spatters or spilled liquids stick to oven walls and between the seal and door surfaces. It is best to wipe up spillovers with a damp cloth right away. Crumbs and spillovers will absorb microwave energy and lengthen cooking times and may even damage the oven. Use a damp cloth to wipe out crumbs that fall between the door and the frame. It is important to keep this area clean to assure a tight seal. Remove greasy spatters with a soapy cloth then rinse and dry. Do not use harsh detergent or abrasive cleaners. The metal tray can be washed by hand or in the dishwasher.

## 2 Keep the outside of the oven clean

Disconnect the mains plug from the power outlet before cleaning the oven to eliminate the possibility of electric shock. Clean the outside of your oven with soap and water then with clean water and dry with a soft cloth or paper towel. To prevent damage to the operating parts inside the oven, the water should not be allowed to seep into the ventilation openings. To clean control panel, open the door to prevent the oven from accidentally starting, and wipe a damp cloth followed immediately by a dry cloth. Press STOP after cleaning.

- 3 If steam accumulates inside or around the outside of the oven door, wipe the panels with a soft cloth. Steam or condensation build up inside the door is normal if foods are heated for a long period on higher power levels, this is not a malfunction. the condensation will eventually evaporate. Try covering the food or vary the heating levels and time to reduce any condensation forming in the door, this may also occur when the oven is operated under high humidity conditions and in no way indicates a malfunction of the unit.
- 4 The door and door seals should be kept clean. Use only warm, soapy water, rinse then dry thoroughly. DO NOT USE ABRASIVE MATERIALS, SUCH AS CLEANING POWDERS OR STEEL AND PLASTIC PADS. Metal parts will be easier to maintain if wiped frequently with a damp cloth.

# USING THE SMART DIAGNOSIS™ FUNCTION

Use this function if you need an accurate diagnosis by an LG Electronics service centre when the product malfunctions or fails. Use this function only to contact the service representative, not during normal operation.

1. When instructed to do so by the call centre, hold the mouthpiece of your phone over the Smart Diagnosis™ logo on the controller.

### NOTE

- Do not touch any other buttons.



2. With the door closed, press and continue to hold the STOP/Cancel button for 3 seconds so that 'Loc' appears on the display. Continue to hold the STOP/Cancel button for a further 5 seconds until '5' appears in the display. (so, the STOP/Cancel button will need to be held for 8 seconds continuously). A tone will then emit from behind the Smart Diagnosis symbol.
3. Keep the phone in place until the tone transmission has finished. The display will count down the time.
4. Once the countdown is over and the tones have stopped, resume your conversation with the call center agent, who will then be able to assist you in using the information transmitted for analysis.

### NOTE

- For best results, do not move the phone while the tones are being transmitted.
- If the call center agent is not able to get an accurate recording of the data, you may be asked to try again.

## QUESTIONS & ANSWERS

FAQ	Answer
What's wrong when the oven light will not glow?	There may be several reasons why the oven light will not glow. Either the light bulb has blown or the electric circuit has failed.
Does microwave energy pass through the viewing screen in the door?	No. The holes, or ports, are made to allow light to pass; they do not let microwave energy through.
Why does the BEEP tone sound when a button on the control panel is touched?	The BEEP tone sounds to assure that the setting is being properly entered.
Will the microwave function be damaged if it operates empty?	Yes. Never run it empty.
Why do eggs sometimes pop?	When baking, frying, or poaching eggs, the yolk may pop due to steam build up inside the yolk membrane. To prevent this, simply pierce the yolk before cooking. Never microwave eggs in the shell.
Why is standing time recommended after microwave cooking is over?	After microwave cooking is finished, food keeps on cooking during standing time. This standing time finishes cooking evenly throughout the food. The amount of standing time depends on the density of the food.
Why doesn't my oven always cook as fast as the cooking guide says?	Check your cooking guide again to make sure you've followed directions correctly, and to see what might cause variations in cooking time. Cooking guide times and heat settings are suggestions, chosen to help prevent overcooking, the most common problem in getting used to this oven. Variations in the size, shape, weight and dimensions of the food require longer cooking time. Use your own judgment along with the cooking guide suggestions to test food conditions, just as you would do with a conventional cooker.
'Food' on the display. Why doesn't the microwave oven work when 'Food' appears on the display?	When 'Food' appears on the display, the microwave will not operate as it assumes that no food has been placed inside. 'Food' in the display will also appear and the remaining time will be cancelled, if the door is opened and closed during cooking and the START button is not pressed within 5 minutes of doing so.
'Cool' appears on the display and the cooling fan continues to run after the cooking or heating time is over.	After cooking is complete, the fan may operate to cool the oven. The display will show 'Cool'. If you open the door or press once STOP before the cooking time is complete, the remaining cooking time will show on the display. This is not a malfunction.

When operating the microwave oven, if you use a product such as radio, TV, wireless LAN, Bluetooth, medical equipment, wireless equipment etc. Using the same frequency as the microwave oven, the product may receive interference from these products. This interference does not indicate a problem of the microwave or the product and is not a malfunction. Therefore, it is safe to use. However, medical equipment may receive interference as well, so use caution when using medical equipment near the product.

# TECHNICAL SPECIFICATIONS

MJ3966ASS / MJ3966ABS / MJ3966AWS		
Power Input	230-240 V~ 50 Hz	
Microwave Output Power.	Max. 1100 watt (IEC60705 rating standard)	
Microwave Frequency	2450 MHz	
Oven Cavity Dimension	395 mm(W) X 262 mm(H) X 378 mm(D)	
Outside Dimension	540 mm(W) X 325 mm(H) X 523 mm(D)	
Net Weight	15.3 kg	
Shipping Weight	21.3 kg	
Power Consumption	Microwave	1350 watt
	Grill	900 watt
	Convection	1750 watt
	Grill Combi.	1400 watt
	Convection Combi.	1800 watt

\* at the 1100 W and 990 W settings (P-HI, & P-90) output power will gradually reduced to avoid overheating.

**Microwave Frequency : 2450 MHz +/- 50 MHz (Group 2 / Class B) \*\***

**Group 2 equipment:** group 2 contains all ISM RF equipment in which radio-frequency energy in the frequency range 9 kHz to 400 GHz is intentionally generated and used or only used, in the form of electromagnetic

**Class B equipment** is equipment suitable for use in domestic establishments and in establishments directly connected to a low voltage power supply network which supplies buildings used for domestic purposes.

You can download the owner's manual at <http://www.lg.com>



**FOR CUSTOMER SERVICE PLEASE CONTACT  
LG SERVICE ON 1300 LG CARE (1300 54 2273) AUSTRALIA,  
OR 0800 LG CARE (0800 54 2273) NEW ZEALAND.**

LG Electronics Australia  
2 Wonderland Drive  
Eastern Creek NSW 2766  
(ABN: 98 064 531 264)

## **LGEAP**

<b>LG Customer Information Centre</b>
All Product related queries or questions Please contact
Toll free number AUSTRALIA <b>1300 54 2273</b> NEW ZEALAND <b>0800 54 2273</b>
Customer Service Website: <a href="http://au.lgservice.com">http://au.lgservice.com</a>
Please refer to the owner's manual for connection and operation related issues, prior to contacting customer information centre.